

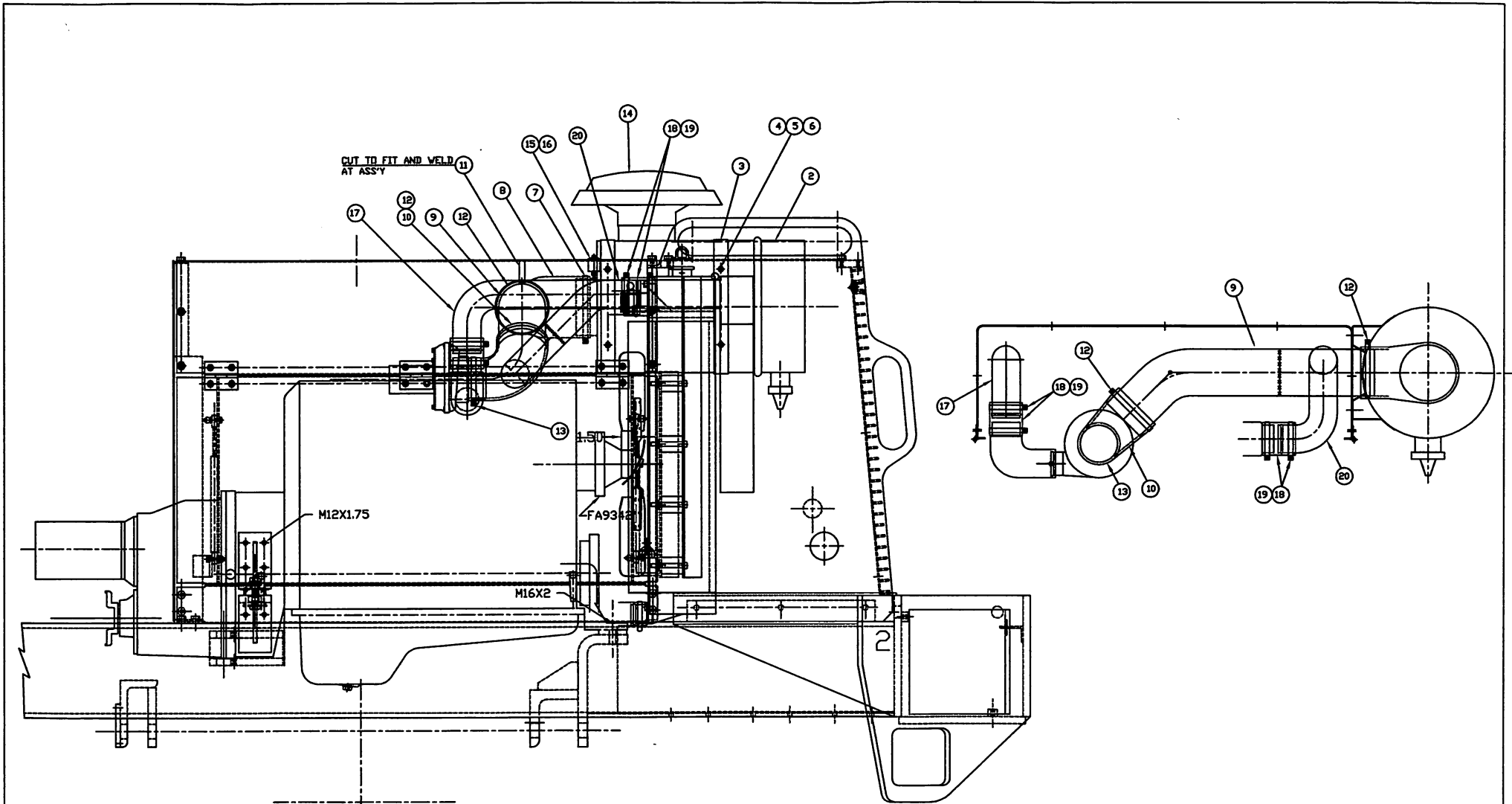

## AIR INTAKE SYSTEM



<p><b>TOLERANCES</b></p> <p>UNLESS OTHERWISE SPECIFIED</p> <p>FRACTIONS +/-</p> <p>3 PLACE DECIMALS +/-</p> <p>2 PLACE DECIMALS +/-</p> <p>1 PLACE DECIMALS +/-</p> <p>ANGLES</p> <p>SEE SWINGMASTER SPECIFICATION</p> <p>0-1 FOR TOLERANCES NOT SPECIFIED</p> <p>DIMENSIONS ARE IN INCHES</p> <p>DO NOT SCALE DRAWING</p> <p>SCALE: 1/4"=1"</p>	<p><b>SWINGMASTER CORPORATION</b></p> <p>11415 MELROSE AVENUE</p> <p>FRANKLIN PARK, ILLINOIS 60151</p>	
	<p>AIR CLEANER INST'L</p>	
	<p>FOR CUMMINS QSB 6.7-160 DIESEL ENGINE</p>	
	<p>MODEL SL181T</p>	
<p>DRAWN BY: J.K.</p> <p>DATE: 11-30-12</p>	<p>DRAWING NO.</p> <p><b>D9-722</b></p>	

SWINGMASTER CORPORATION

PARTS BOOK

MACHINE

SECTION

10

MODEL 181 SWINGLOADER

ENGINE AIR INTAKE SYSTEM

ASSEMBLY  
NUMBER

DESCRIPTION

1807014 AIR CLEANER INS'L

ITEM NO.	PART NUMBER	DESCRIPTION	QTY USED
2	1802813	AIR CLEANER	1
3	1802812	AIR CLEANER MOUNTING BRACKET	2
4	1805307	HHCS 7/16-14X3/4"LG	4
5	1802557	HEX NUT 7/16-14	4
6	1800569	7/16" LOCK WASHER	4
7	1805562	CLAMP	1
8	1803336	90 DEG. RUBBER ELBOW - 5" TO 6"	1
9	1806158	TUBE WELDMENT	1
10	1803335	90 DEG. RUBBER ELBOW - 4" TO 5"	1
11	1805762	STRAP HANGER CLAMP	1
12	1805564	CLAMP	2
13	1800690	4 3/4" HOSE CLAMP	1
14	1802811	AIR CLEANER LID	1
15	1805266	INFORMER GAGE BNSPL	1
16	1800201	FILTER ADAPTER	1
17	1806985	L.H. CAC TUBE WLD'T	1
18	1806376	SIL. HOSE-3" LONG	4
19	1806269	CLAMP	8
20	1806986	R.H. CAC. TUBE WLD'T	1