

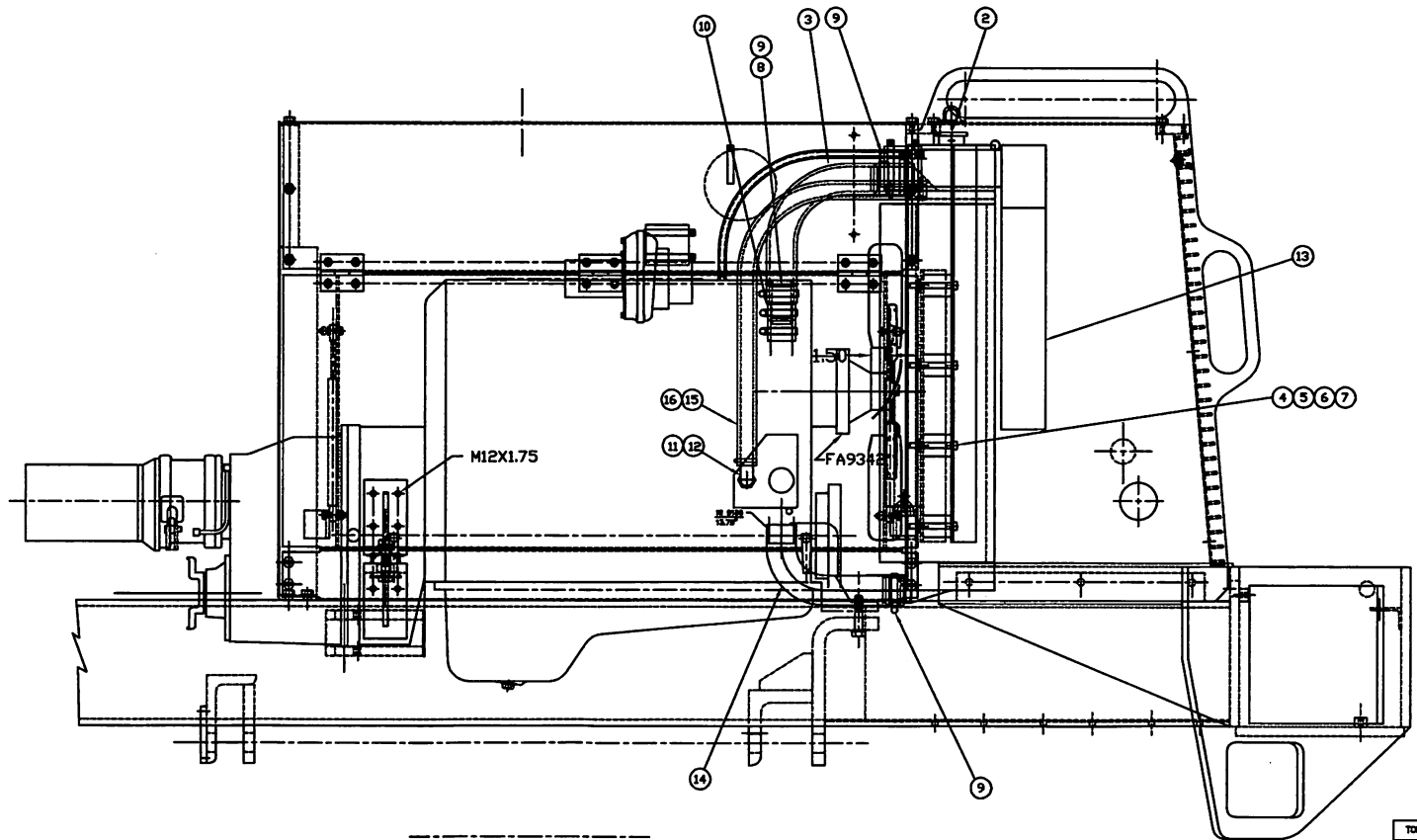

COOLING SYSTEM



**TOLERANCES**  
 UNLESS OTHERWISE SPECIFIED  
 FRACTIONS +/-  
 3 PLACE DECIMALS +/-  
 2 PLACE DECIMALS +/-  
 1 PLACE DECIMALS +/-  
 ANGLES  
 SEE SWINGMASTER SPECIFICATION  
 0-1 FOR TOLERANCES NOT SPECIFIED  
 DIMENSIONS ARE IN INCHES  
 DO NOT SCALE DRAWING  
 SCALE: 1/4

**SWINGMASTER CORPORATION**  
 11415 MELROSE AVENUE  
 FRANKLIN PARK, ILLINOIS 60131  
**RADIATOR INSTALLATION**  
 FOR CUMMINS QSB 6.7-160 DIESEL ENGINE  
 MODEL 1617  
 DRAWN BY: J.K.      DRAWING NO.  
 DATE: 10-10-06      D3-401

SWINGMASTER CORPORATION

PARTS BOOK

---

MACHINE	SECTION	12
-----	-----	-----
MODEL 181 SWINGLOADER	COOLING SYSTEM	

---

ASSEMBLY NUMBER	DESCRIPTION
-----	-----
1806360	RADIATOR INSTALLATION

ITEM NO.	PART NUMBER	DESCRIPTION	QTY USED
-----	-----	-----	-----
2	1805598	RADIATOR CAP - 10 LBS	1
3	1806421	RAD. HOSE - 2" I.D.	1
4	1800463	H.H.C.S. 3/8-16 X 3 1/2" LONG	8
5	1800515	ESNA HEX NUT 3/8-16	8
6	1800552	3/8" FLAT WASHER	12
7	1806361	HOSE BEAD TO MALE PIPE 90	1
8	1802801	HOSE CLAMP - 3"	6
9	1806362	PIPE ADAPTER	1
10	1806363	PIPE REDUCER	1
11	1806273	RADIATOR W/ CAC.	1
12	1805640	RAD. HOSE	1
13	1802802	FC-350-16 BULK HOSE / (IN)	1
14	1805642	HOSE CLAMP	2
15	1801291	RUBBER MOUNT	8
16	1806940	SHROUD	1
17	1806129	HOSE ADAPTOR	1
18	1806123	HOSE BEAD TO MALE PIPE	1
19	1806131	HOSE CLAMP	2
20	1806132	HOSE 3/8" ID. / (IN)	32
21	1806133	HOSE BEAD TO MALE PIPE	1