

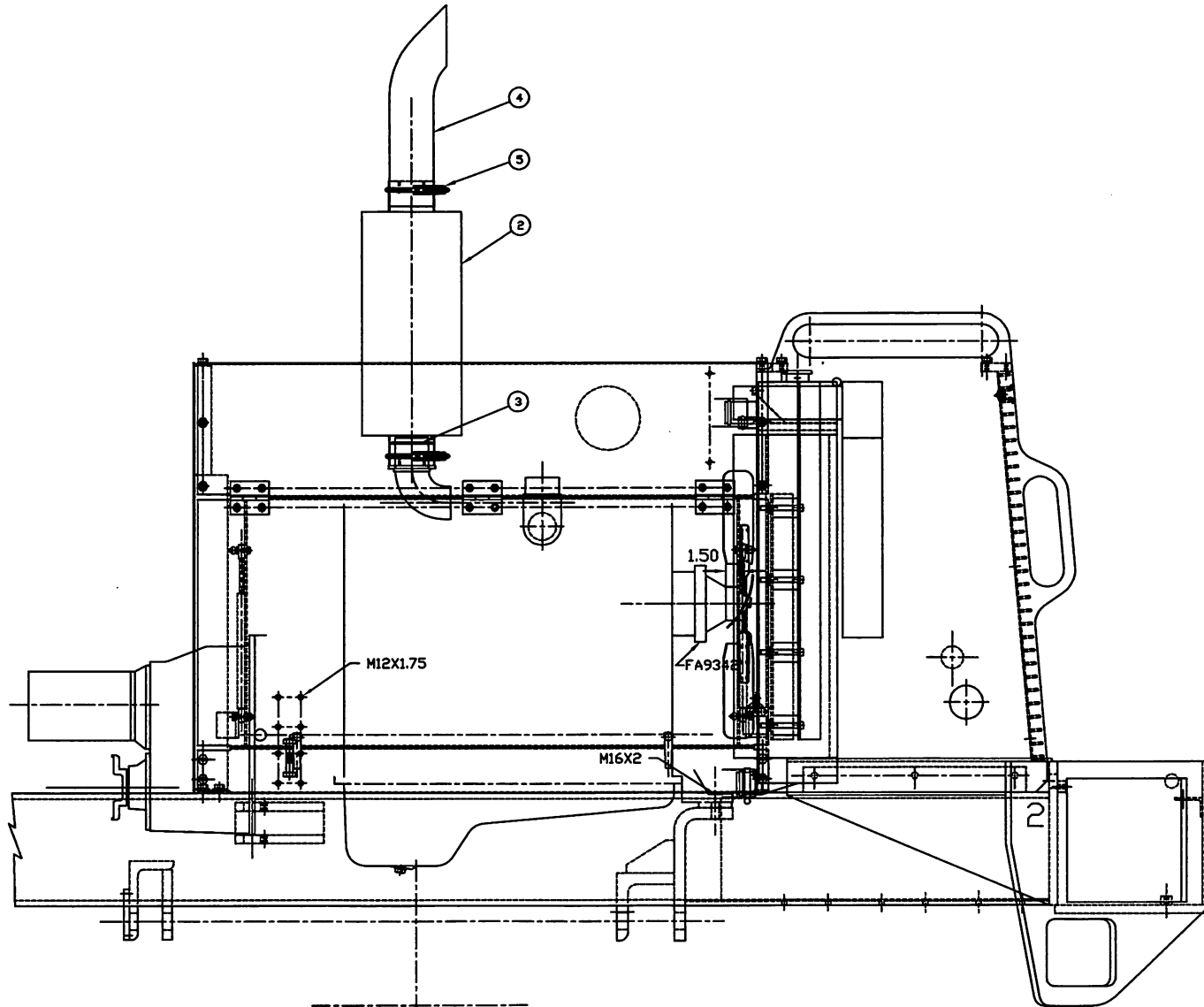

EXHAUST SYSTEM



<p>TOLERANCES UNLESS OTHERWISE SPECIFIED FRACTIONS +/- 3 PLACE DECIMALS +/- 2 PLACE DECIMALS +/- 1 PLACE DECIMALS +/- ANGLES</p> <p>SEE SWINGMASTER SPECIFICATION 0-1 FOR TOLERANCES NOT SPECIFIED</p> <p>DIMENSIONS ARE IN INCHES DO NOT SCALE DRAWING SCALE: 1/8"</p>	<p>SWINGMASTER CORPORATION 11415 MELROSE AVENUE FRANKLIN PARK, ILLINOIS 60131</p>	
	<p>MUFFLER INSTALLATION FOR CUMMINS QSB 6.7-160 DIESEL ENGINE</p>	
<p>MODEL SL181T</p>	<p>DRAWN BY: JJK</p>	<p>DRAWING NO. D4-399</p>
<p>DATE: 6-12-07</p>		

SWINGMASTER CORPORATION

PARTS BOOK

MACHINE	SECTION	11
MODEL 181 SWINGLOADER	ENGINE EXHAUST SYSTEM	

ASSEMBLY NUMBER	DESCRIPTION
1807015	MUFFLER INST'L

ITEM NO.	PART NUMBER	DESCRIPTION	QTY USED
2	1806987	MUFFLER	1
3	1806981	EXHAUST ADAPTER	1
4	1803342	4" I.D. X 18" LONG CURVED STACK	1
5	1803944	MUFFLER CLAMP - 4 1/8"	2