

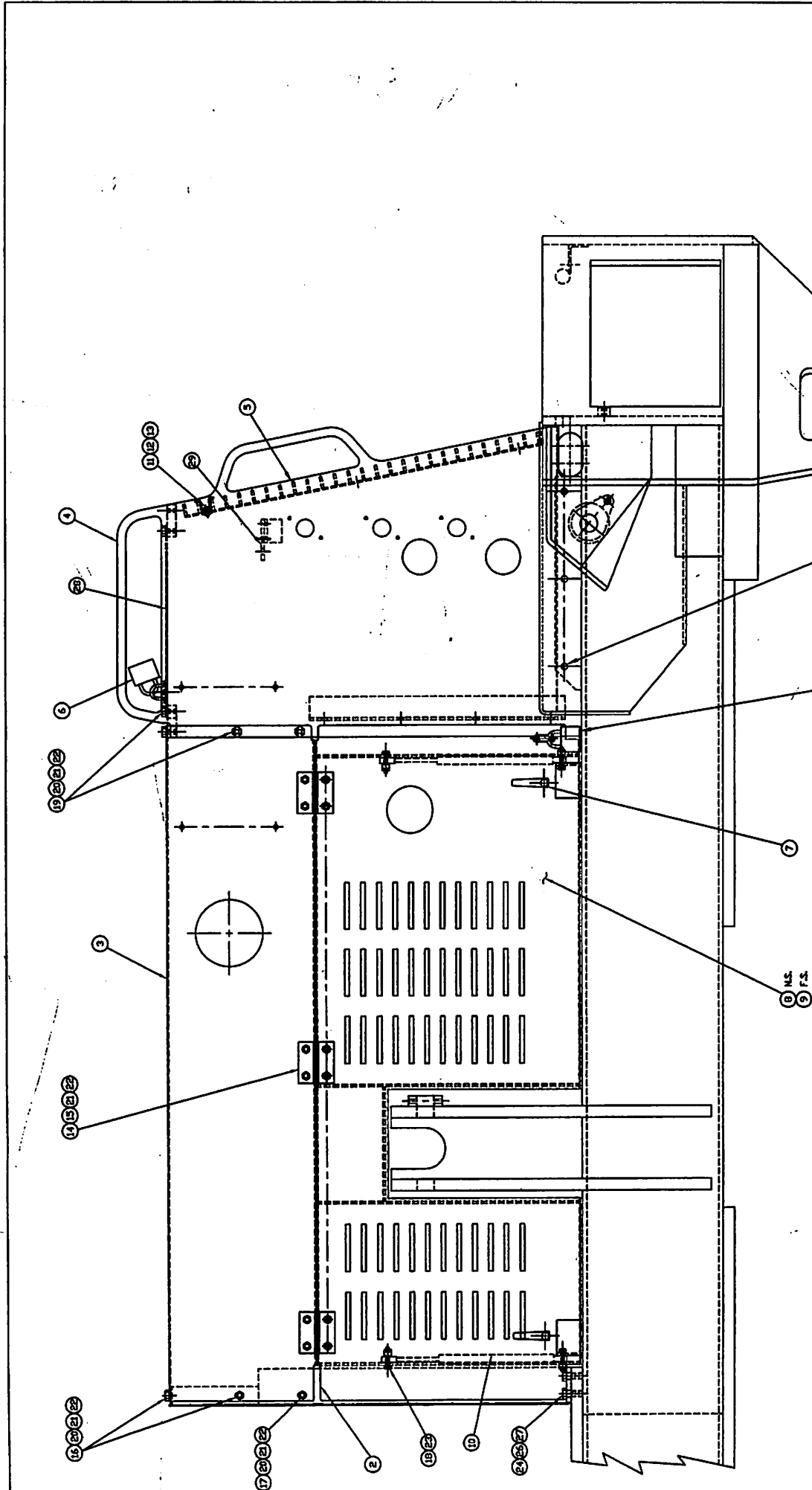

SECTION N

COVERS
AND
GRILL



| | |
|---|---|
| SWINGMASTER CORPORATION 1140 WILSON AVENUE PRINCETON PARK, CLACKAMAS, OREGON | |
| ENGINE COVERS INSTALLATION FOR CUMMINS 6B8.7 DIESEL ENGINE | |
| MODEL SL180 | DRAWING NO. D4-791 |
| DRAWN BY: J.A. DATE: 11-08-66 | SEE SWINGMASTER SPECIFICATION 6-1 FOR TOLERANCES NOT SPECIFIED DIMENSIONS ARE IN INCHES UNLESS OTHERWISE SPECIFIED SCALE: 1/4" = 1" |
| TOLERANCES UNLESS OTHERWISE SPECIFIED FINISHES: ALL SURFACES 1/16" FRACTIONS ± .005 3/16" FRACTIONS ± .005 1/2" FRACTIONS ± .005 1" FRACTIONS ± .005 | 1 INSTALLATION |

MACHINE

SECTION

1

MODEL SL180-13 SWINGLOADER

COVERS AND GRILL

| ASSEMBLY | | DESCRIPTION | QTY USED |
|-------------|----------------|--------------------------------|-------------|
| NUMBER | | | |
| | 1806724 | ENGINE COVER INSTALLATION | |
| ITEM NO. | PART NUMBER | DESCRIPTION | QTY USED |
| 2 | 1805781 | HOOD SUPPORT | 1 |
| 3 | 1806725 | ENGINE HOOD | 1 |
| 4 | 1806726 | GRILL WELDMENT | 1 |
| 5 | 1806727 | STEEL GRATING | 1 |
| 6 | 1800175 | PADLOCK AND KEY | 3 |
| 7 | 1800196 | LATCH | 4 |
| 8 | 1806728 | ENGINE SIDE COVER - L.H. | 1 |
| 9 | 1806729 | ENGINE SIDE COVER - R.H. | 1 |
| 10 | 1800183 | GAS SPRING | 4 |
| 11 | 1800439 | H.H.C.S. 1/4-20 X 1 1/2" LONG | 6 |
| 12 | 1800186 | STEEL ANCHOR CLIPS | 6 |
| 13 | 1800673 | 1/4-20 CLIP NUT | 6 |
| 14 | 1800310 | HINGE 3" x 3.5" LG. | 6 |
| 15 | 1801430 | H.H.C.S. 5/16-18 X 5/8" LONG | 24 |
| 16 | 1800442 | H.H.C.S. 5/16-18 X 3/4" LONG | 5 |
| 17 | 1800443 | H.H.C.S. 5/16-18 X 1" LONG | 2 |
| 18 | 1800444 | H.H.C.S. 5/16-18 X 1 1/4" LONG | 8 |
| 19 | 1800445 | H.H.C.S. 5/16-18 X 1 1/2" LONG | 17 |
| 20 | 1800550 | 5/16" FLAT WASHER | 24 |
| 21 | 1800074 | 5/16" LOCK WASHER | 48 |
| 22 | 1800512 | HEX NUT 5/16-18 | 48 |
| 23 | 1800513 | ESNA HEX NUT 5/16-18 | 8 |
| 24 | 1800469 | H.H.C.S. 1/2-13 X 1" LONG | 4 |
| 25 | 1800471 | H.H.C.S. 1/2-13 X 1 1/2" LONG | 6 |
| 26 | 1800570 | 1/2" LOCK WASHER | 10 |
| 27 | 1800554 | 1/2" FLAT WASHER | 4 |
| 28 | 1806405 | RADIATOR COVER PLATE WELDMENT | 1 |
| 29 | 1806278 | LIGHTS MTG. BAR | 1 |

SWINGMASTER CORPORATION

11415 MELROSE AVENUE

FRANKLIN PARK, ILLINOIS 60131

TEL: (847) 451-1224

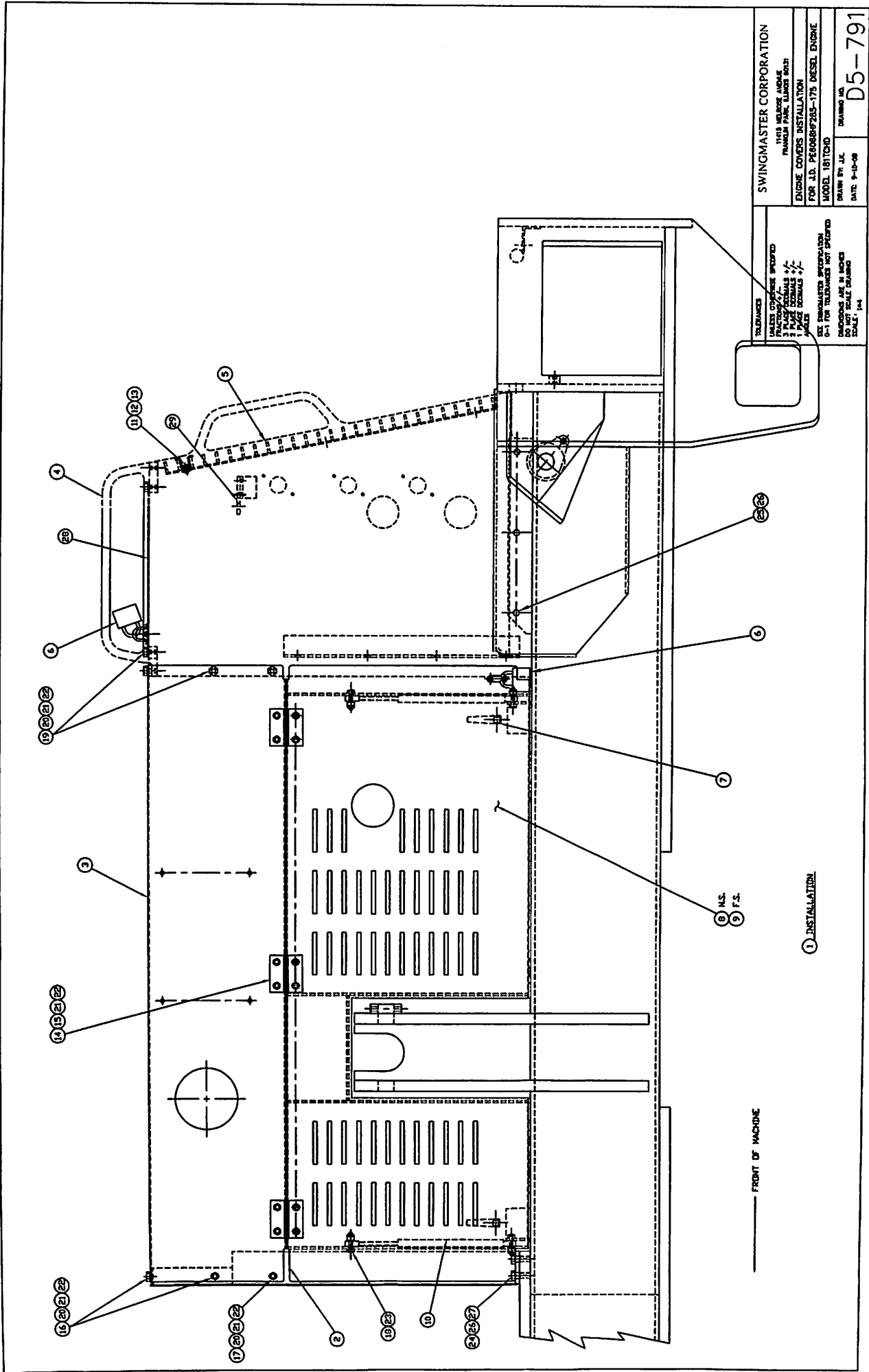

SWINGMASTER CORPORATION

11518 WILSON AVENUE
PRINCETON PARK, LINDSEY BOULDER

ENGINE COVERS INSTALLATION

FOR J.D. PERGEMER 200C-175 DIESEL ENGINE

MODEL 18111CHD

DRAWN BY: J.K.
DATE: 9-10-08

D5-791

TOLERANCES UNLESS OTHERWISE SPECIFIED
 1 HOLE DIMENSIONS ±.005
 2 HOLE DIMENSIONS ±.010
 3 HOLE DIMENSIONS ±.015
 4 HOLE DIMENSIONS ±.020
 5 HOLE DIMENSIONS ±.030
 6 HOLE DIMENSIONS ±.040
 7 HOLE DIMENSIONS ±.050
 8 HOLE DIMENSIONS ±.060
 9 HOLE DIMENSIONS ±.070
 10 HOLE DIMENSIONS ±.080
 11 HOLE DIMENSIONS ±.090
 12 HOLE DIMENSIONS ±.100
 13 HOLE DIMENSIONS ±.120
 14 HOLE DIMENSIONS ±.150
 15 HOLE DIMENSIONS ±.200
 16 HOLE DIMENSIONS ±.250
 17 HOLE DIMENSIONS ±.300
 18 HOLE DIMENSIONS ±.350
 19 HOLE DIMENSIONS ±.400
 20 HOLE DIMENSIONS ±.450
 21 HOLE DIMENSIONS ±.500
 22 HOLE DIMENSIONS ±.550
 23 HOLE DIMENSIONS ±.600
 24 HOLE DIMENSIONS ±.650
 25 HOLE DIMENSIONS ±.700
 26 HOLE DIMENSIONS ±.750
 27 HOLE DIMENSIONS ±.800

FRONT OF MACHINE

1 - INSTALLATION

8 N.S.
9 F.S.

MACHINE

SECTION

1

MODEL SL180-13 SWINGLOADER

COVERS AND GRILL

| ASSEMBLY | | DESCRIPTION | QTY USED |
|-------------|----------------|--------------------------------|-------------|
| NUMBER | | | |
| | 1806860 | ENGINE COVER INSTALLATION | |
| ITEM NO. | PART NUMBER | DESCRIPTION | QTY USED |
| 2 | 1805781 | HOOD SUPPORT | 1 |
| 3 | 1806861 | ENGINE HOOD | 1 |
| 4 | 1806862 | GRILL WELDMENT | 1 |
| 5 | 1806727 | STEEL GRATING | 1 |
| 6 | 1800175 | PADLOCK AND KEY | 3 |
| 7 | 1800196 | LATCH | 4 |
| 8 | 1806863 | ENGINE SIDE COVER - L.H. | 1 |
| 9 | 1806864 | ENGINE SIDE COVER - R.H. | 1 |
| 10 | 1800183 | GAS SPRING | 4 |
| 11 | 1800439 | H.H.C.S. 1/4-20 X 1 1/2" LONG | 6 |
| 12 | 1800186 | STEEL ANCHOR CLIPS | 6 |
| 13 | 1800673 | 1/4-20 CLIP NUT | 6 |
| 14 | 1800310 | HINGE 3" x 3.5" LG. | 6 |
| 15 | 1801430 | H.H.C.S. 5/16-18 X 5/8" LONG | 24 |
| 16 | 1800442 | H.H.C.S. 5/16-18 X 3/4" LONG | 5 |
| 17 | 1800443 | H.H.C.S. 5/16-18 X 1" LONG | 2 |
| 18 | 1800444 | H.H.C.S. 5/16-18 X 1 1/4" LONG | 8 |
| 19 | 1800445 | H.H.C.S. 5/16-18 X 1 1/2" LONG | 17 |
| 20 | 1800550 | 5/16" FLAT WASHER | 24 |
| 21 | 1800074 | 5/16" LOCK WASHER | 48 |
| 22 | 1800512 | HEX NUT 5/16-18 | 48 |
| 23 | 1800513 | ESNA HEX NUT 5/16-18 | 8 |
| 24 | 1800469 | H.H.C.S. 1/2-13 X 1" LONG | 4 |
| 25 | 1800471 | H.H.C.S. 1/2-13 X 1 1/2" LONG | 6 |
| 26 | 1800570 | 1/2" LOCK WASHER | 10 |
| 27 | 1800554 | 1/2" FLAT WASHER | 4 |
| 28 | 1806405 | RADIATOR COVER PLATE WELDMENT | 1 |
| 29 | 1806278 | LIGHTS MTG. BAR | 1 |

SWINGMASTER CORPORATION

11415 MELROSE AVENUE

FRANKLIN PARK, ILLINOIS 60131

TEL: (847) 451-1224

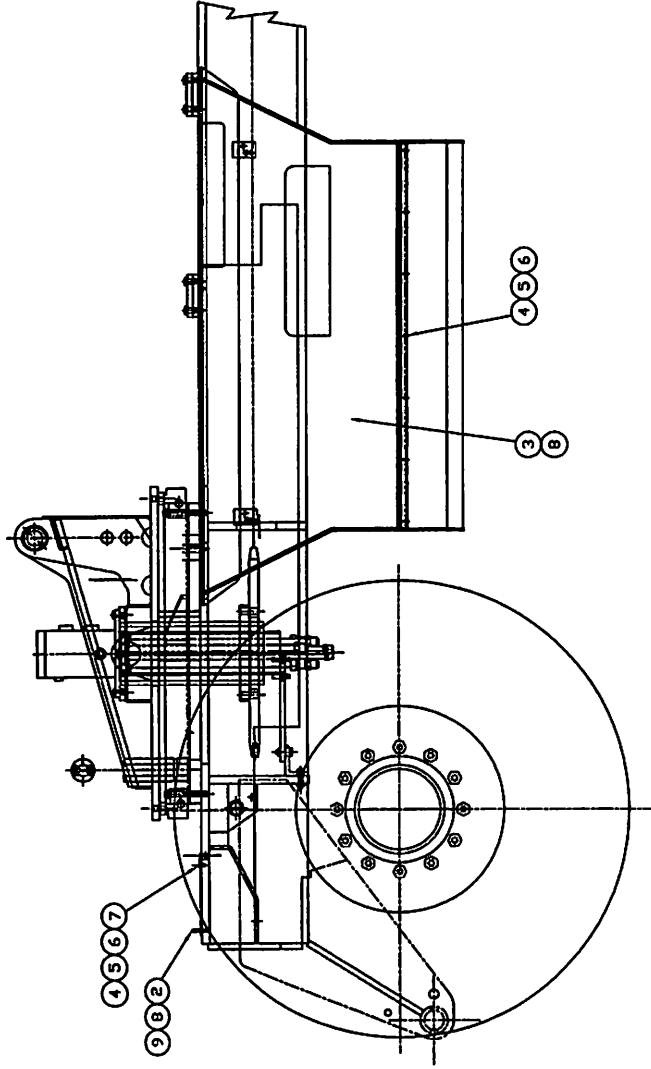

TOLERANCES

UNLESS OTHERWISE SPECIFIED
 FRACTIONS +/-
 3 PLACE DECIMALS +/-
 2 PLACE DECIMALS +/-
 1 PLACE DECIMALS +/-
 ANGLES

SEE SWINGMASTER SPECIFICATION
 G-1 FOR TOLERANCES NOT SPECIFIED
 DIMENSIONS ARE IN INCHES
 DO NOT SCALE DRAWING
 SCALE: 1=12

SWINGMASTER CORPORATION

11415 MELROSE AVENUE
 FRANKLIN PARK, ILLINOIS 60131

FENDER & FRONT TOOL BOX COVER INST'L

MODEL 181TCHD

DRAWN BY: J.K.

DATE: 1-15-09

DRAWING NO.

C1-409

MACHINE

SECTION

1

MODEL SL180-13 SWINGLOADER

COVERS AND GRILL

ASSEMBLY
NUMBER

DESCRIPTION

1806886 FENDER & FRONT TOOL BOX COVER INST'L

| ITEM NO. | PART NUMBER | DESCRIPTION | QTY USED |
|-------------|----------------|----------------------------|-------------|
| 2 | 1806887 | FRONT TOOL BOX COVER PLATE | 1 |
| 3 | 1806235 | FENDR COVER WELDMENT | 1 |
| 4 | 1800443 | H.H.C.S. 5/16-18 X 1" LONG | 15 |
| 5 | 1800074 | 5/16" LOCK WASHER | 15 |
| 6 | 1800512 | HEX NUT 5/16-18 | 15 |
| 7 | 1800310 | HINGE 3" x 3.5" LG. | 2 |
| 8 | 1800175 | PADLOCK AND KEY | 2 |
| 9 | 1803326 | U-BOLT | 1 |

SWINGMASTER CORPORATION

11415 MELROSE AVENUE

FRANKLIN PARK, ILLINOIS 60131

TEL: (847) 451-1224