



SECTION M
FUEL SYSTEM

SWINGMASTER CORPORATION

PARTS BOOK

MACHINE

SECTION

M

MODEL 361 SWINGLOADER

FUEL SYSTEM

DESCRIPTION

FUEL TANK INSTALLATION

FUEL SYSTEM LINES AND FITTINGS

SWINGMASTER CORPORATION
11415 MELROSE AVENUE
FRANKLIN PARK, ILLINOIS 60131

TELEPHONE: (847) 451-1224

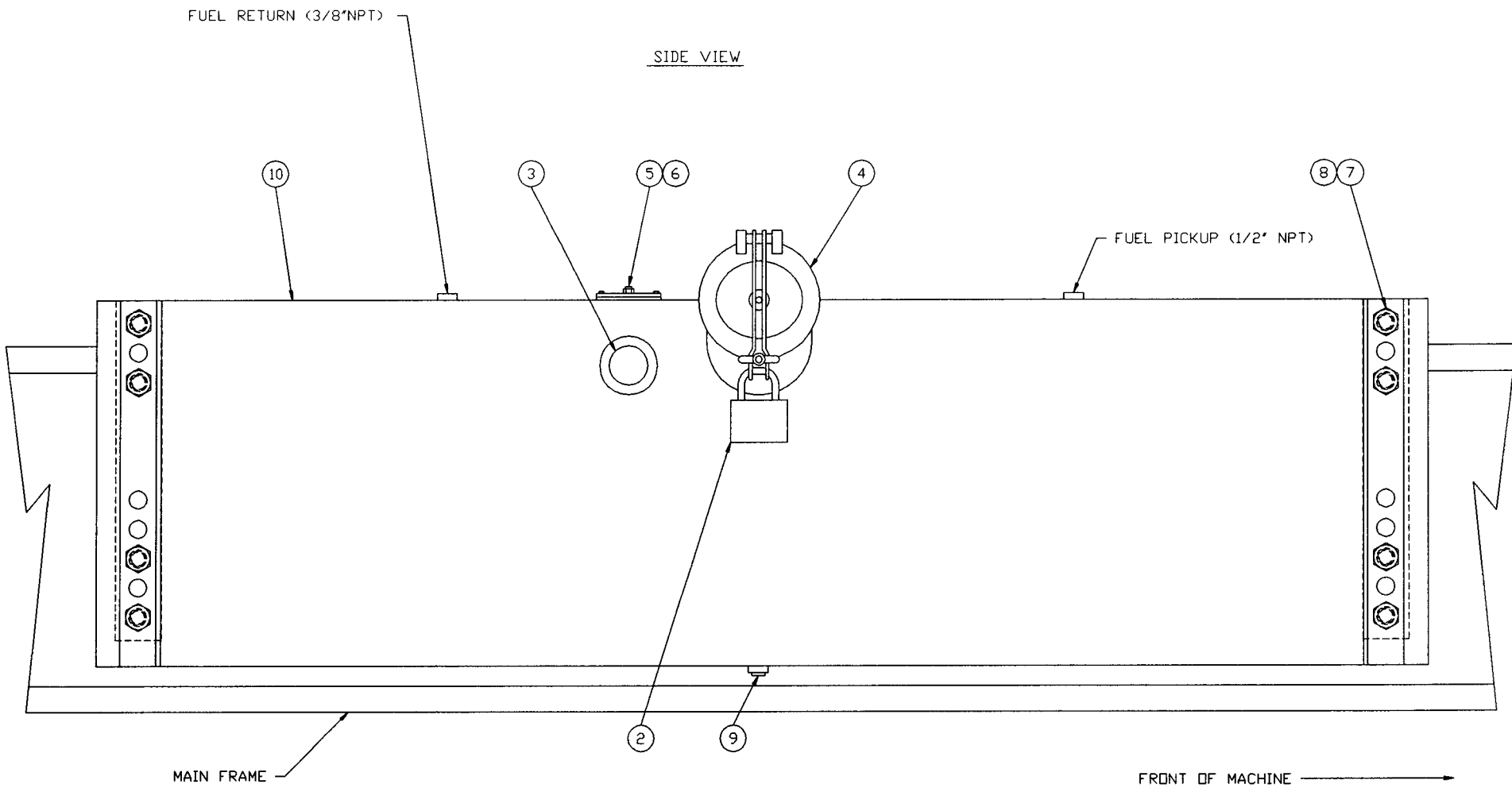

① INSTALLATION

TOLERANCES
 UNLESS OTHERWISE SPECIFIED
 FRACTIONS +/-
 3 PLACE DECIMALS +/-
 2 PLACE DECIMALS +/-
 1 PLACE DECIMALS +/-
 ANGLES

SEE SWINGMASTER SPECIFICATION
 G-1 FOR TOLERANCES NOT SPECIFIED

DIMENSIONS ARE IN INCHES
 DO NOT SCALE DRAWING
 SCALE: 1=3

SWINGMASTER CORPORATION
 11415 MELROSE AVENUE
 FRANKLIN PARK, ILLINOIS 60131

FUEL TANK INSTALLATION

MODEL 361

DRAWN BY: R.O. DRAWING NO.
 DATE: 11-29-88 C-133

1	12-18-90
REV. NO.	DATE

MACHINE	SECTION	13
MODEL 361 SWINGLOADER	FUEL SYSTEM	

ASSEMBLY NUMBER	DESCRIPTION
1802212	FUEL TANK INSTALLATION

ITEM PART NO. NUMBER DESCRIPTION	QTY. USED
2 1804475 PADLOCK AND KEY	1
3 1800270 SIGHT GAUGE - 1 1/2" NPT	1
4 1802213 PROTECTOSEAL FILLER CAP	1
5 1800276 FUEL LEVEL SENDER - INCLUDES ITEM 5a	1
5a 8700742 BRASS FLOAT - (NOT SHOWN IN PICTURE)	1
6 1800287 GASKET - FOR FUEL LEVEL SENDER	1
7 1802214 H.H.C.S. 5/8-11 X 1 1/4" LONG	8
8 1800022 5/8" LOCK WASHER	8
9 1800017 1/2" PIPE PLUG - HEX HEAD	1
10 1802215 FUEL TANK - CAPACITY 50 GALLONS	1

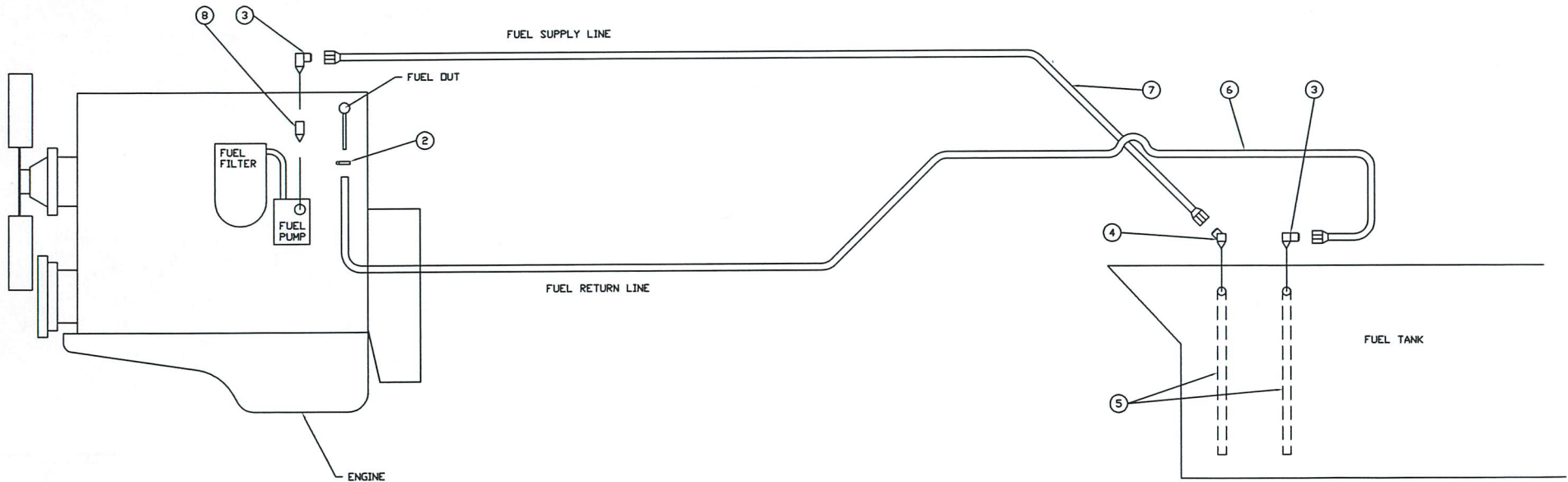

① INSTALLATION

TOLERANCES UNLESS OTHERWISE SPECIFIED FRACTIONS +/- 3 PLACE DECIMALS +/- 2 PLACE DECIMALS +/- 1 PLACE DECIMALS +/- ANGLES	SWINGMASTER CORPORATION 11415 MELROSE AVENUE FRANKLIN PARK, ILLINOIS 60131	
	ENGINE FUEL SYSTEM LINES AND FITTINGS FOR CUMMINS 6B5.9 DIESEL ENGINE	
SEE SWINGMASTER SPECIFICATION 0-1 FOR TOLERANCES NOT SPECIFIED	MODEL 181	
DIMENSIONS ARE IN INCHES DO NOT SCALE DRAWING SCALE: NONE	DRAWN BY: R.O. DATE: 4-9-90	DRAWING NO. D2-89

3480

MACHINE	SECTION	13
-----	-----	-----
MODEL 361 SWINGLOADER	FUEL SYSTEM	
-----	-----	-----

ASSEMBLY NUMBER	DESCRIPTION
-----	-----
1803480	FUEL SYSTEM LINES & FITTINGS

ITEM NO.	PART NUMBER	DESCRIPTION	QTY USED
-----	-----	-----	-----
2	1800691	1 1/16" HOSE CLAMP	1
3	1800783	90 DEG MALE ELBOW 1/2 PIPE TO 1/4 TUBE	2
4	1800849	45 DEG MALE ELBOW 1/2 TUBE TO 1/2 PIPE	1
5	1800966	3/8 PIPE 19 3/4 LG THREADED ON ONE SIDE	2
6	1803171	HOSE ASSEMBLY 2556-4	1
7	1803701	HOSE ASSEMBLY 2556-8	1
8	8702782	FUEL FLOW CHECK VALVE	1