

SECTION H

PARKING
BRAKE
SYSTEM

← FRONT OF MACHINE

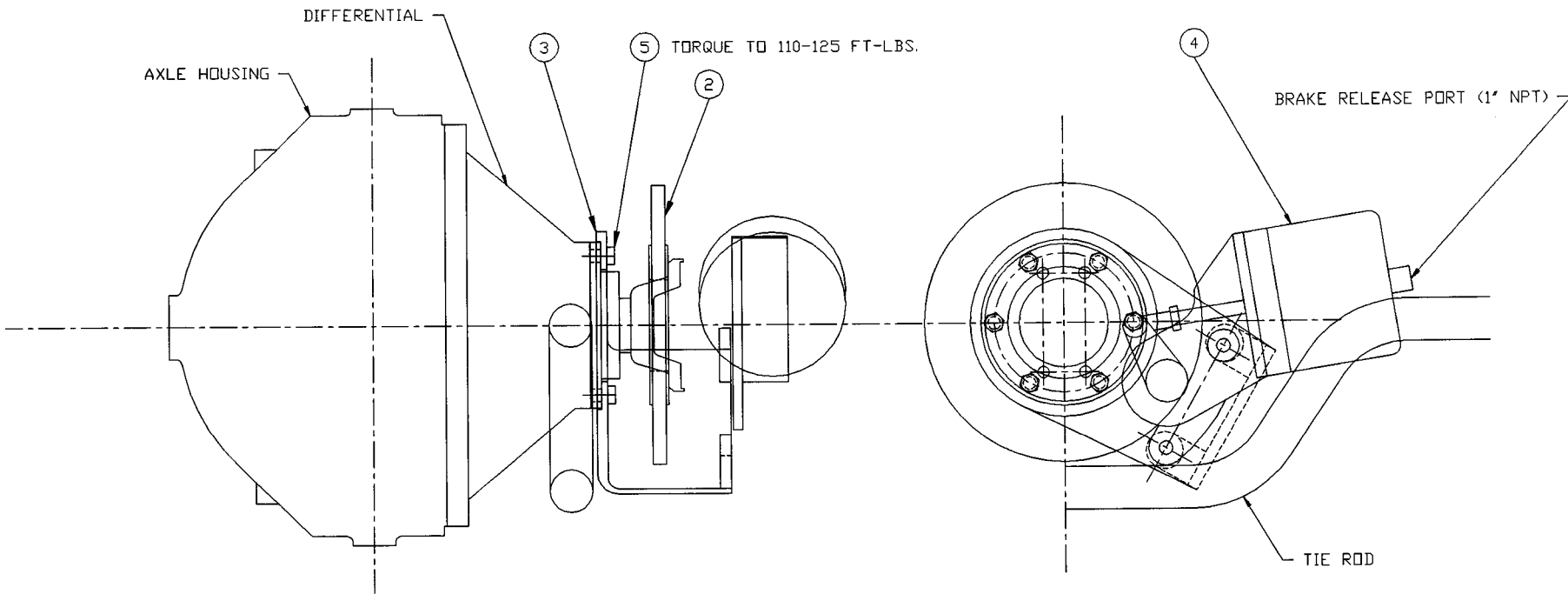

① INSTALLATION

INSTALLATION NOTE:

1. INSTALL AIR LINE AND APPLY A MINIMUM OF 60 PSI AIR PRESSURE.
2. PLACE CALIPER OVER DISC.
3. ACTUATE CALIPER 10 TIMES BY DROPPING AIR PRESSURE.
4. CHECK CLEARANCE BETWEEN BRAKE AND PADS AND DISC. CLEARANCE SHOULD BE 0.015 INCH MINIMUM AND 0.030 MAXIMUM WITH AIR PRESSURE APPLIED.
5. TO ADJUST CLEARANCE, REMOVE PLASTIC CAP FROM CENTER OF ACTUATOR LEVER. INSERT 1/4" HEX WRENCH AND ROTATE SHAFT TO OBTAIN PROPER CLEARANCE. REPLACE PLASTIC CAP.

WARNING:

DO NOT ATTEMPT TO OPEN THE SPRING CHAMBER.
DANGEROUS SPRING PRELOAD.
SEVERE INJURY MAY RESULT.

TO SERVICE AIR CHAMBER, SEE GUSTIN BACON BULLETIN.
HAYES BRAKE RECOMMENDED THAT INEXPERIENCED PERSONNEL
DO NOT ATTEMPT TO SERVICE THE SPRING CHAMBER.

TOLERANCES	SWINGMASTER CORPORATION	
UNLESS OTHERWISE SPECIFIED FRACTIONS +/- 3 PLACE DECIMALS +/- 2 PLACE DECIMALS +/- 1 PLACE DECIMALS +/- ANGLES	11415 MELROSE AVENUE FRANKLIN PARK, ILLINOIS 60131	
SEE SWINGMASTER SPECIFICATION G-1 FOR TOLERANCES NOT SPECIFIED	PARKING BRAKE ASS'Y INSTALLATION	
DIMENSIONS ARE IN INCHES DO NOT SCALE DRAWING SCALE: 1=4	SPRING APPLIED AIR RELEASED	
	MODEL 361 & SL180	
	DRAWN BY: J.K.	DRAWING NO.
	DATE: 8-16-88	C-111

MACHINE	SECTION	8
MODEL SL180 SWINGLOADER	PARKING BRAKE SYSTEM	

ASSEMBLY NUMBER	DESCRIPTION
1802206	PARKING BRAKE ASSEMBLY INSTALLATION

ITEM NO.	PART NUMBER	DESCRIPTION	QTY. USED
002	1802207	YOKE & DISC PLATE WELDMENT	1.00
003	1802208	PARKING BRAKE MOUNTING BRACKET WELDMENT	1.00
004	1802209	PARKING BRAKE ASSEMBLY	1.00
005	1802210	H.H.C.S. 9/16-12 X 1 3/4" LONG	6.00

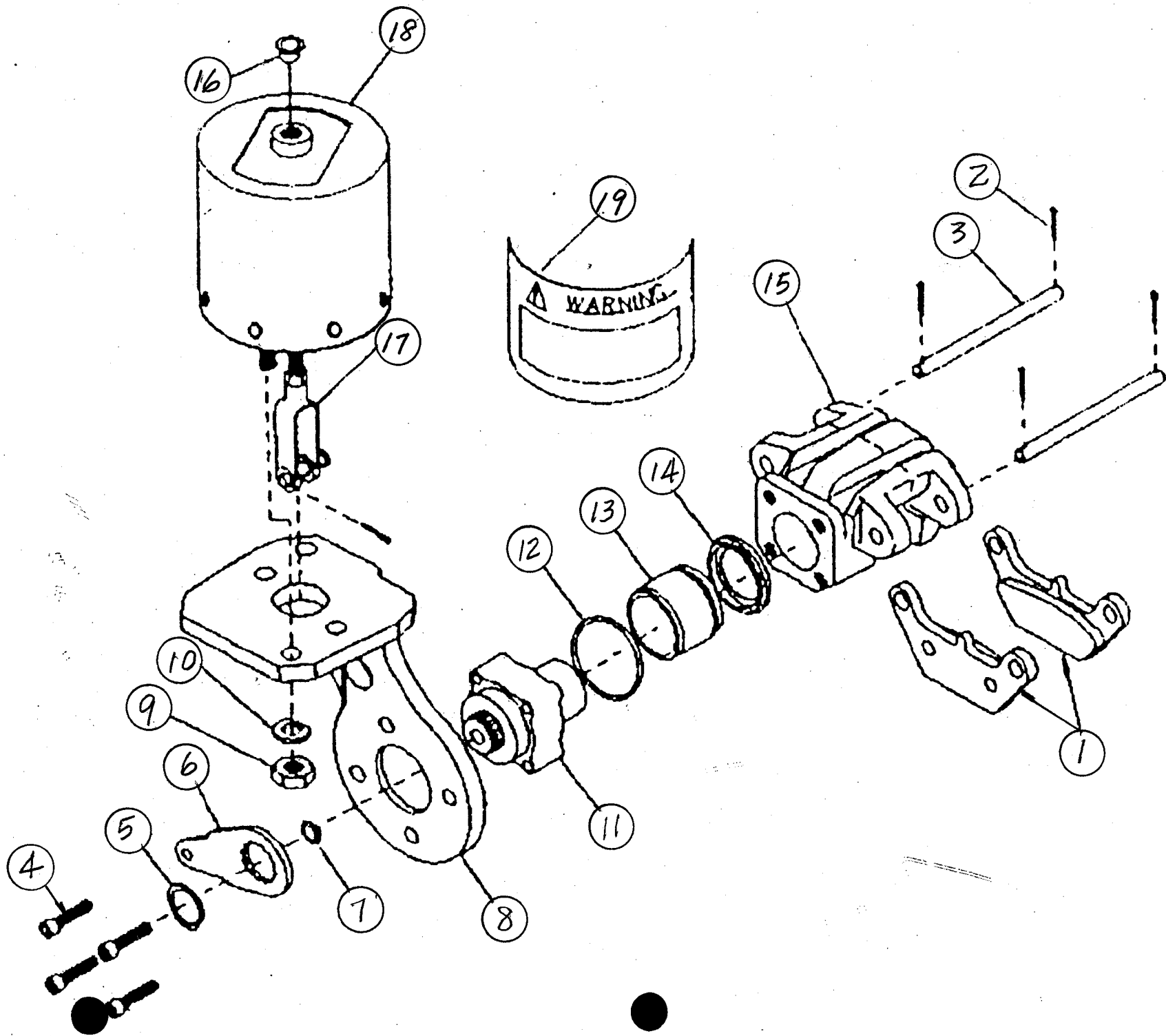

MACHINE

SECTION

8

MODEL 361 SWINGLOADER

PARKING BRAKE SYSTEM

ASSEMBLY
NUMBER

DESCRIPTION

1802209

PARKING BRAKE ASSEMBLY

ITEM NO.	PART NUMBER	DESCRIPTION	QTY. USED
001	8702658	PAD & HOLDER ASSEMBLY	2.00
002	8702659	COTTER PIN	4.00
003	8702660	MOUNTING PIN	2.00
004	8704088	COVER BOLT	4.00
005	8704089	RETAINING RING	1.00
006	8702663	LEVER	1.00
007	8704090	CAP PLUG	1.00
008	8704091	BRACKET	1.00
009	8702667	HEX NUT	2.00
010	8702668	WASHER	2.00
011	8704092	CW. ACTUATOR	1.00
012	8702665	DUST BOOT	1.00
013	8704093	PISTON	1.00
014	8702676	DUST BOOT	1.00
015	8704094	CASTING	1.00
016	8704095	CAP PLUG	1.00
017	8704096	CLEVIS	1.00
018	8704097	SPRING ACTUATOR	1.00
019	8704098	WARNING LABEL	1.00

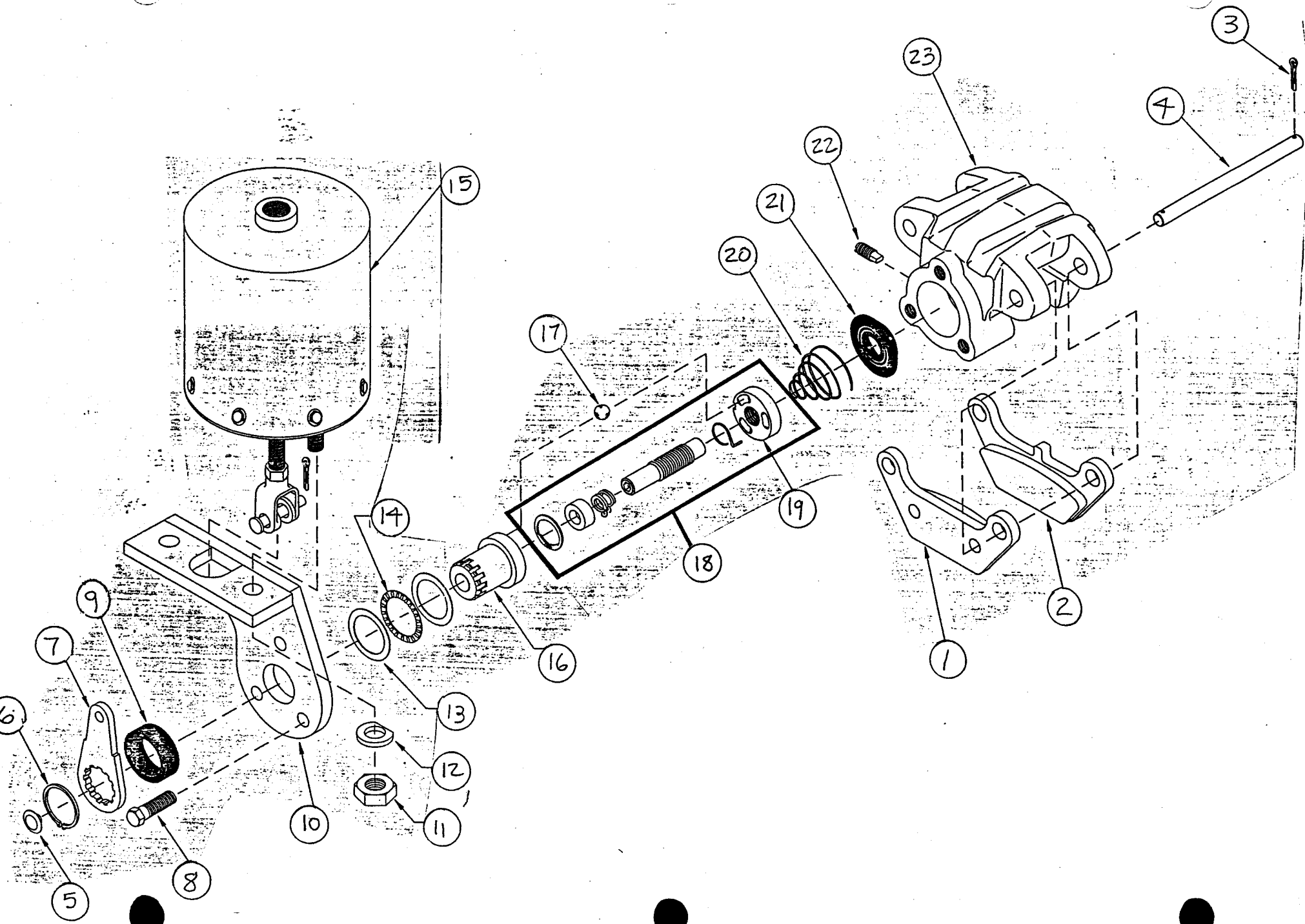

MACHINE	SECTION	8
MODEL 181 SWINGLOADER	PARKING BRAKE SYSTEM	

ASSEMBLY
NUMBER

DESCRIPTION

1802209

PARKING BRAKE ASSEMBLY

ITEM NO.	PART NUMBER	DESCRIPTION	QTY. USED
1	8702657	PAD & HOLDER ASSEMBLY	1
2	8702658	PAD & HOLDER ASSEMBLY	1
3	8702659	COTTER PIN	4
4	8702660	MOUNTING PIN	2
5	8702661	PLUG	1
6	8702662	RETAINING RING	1
7	8702663	LEVER	1
8	8702664	CAP SCREW	3
9	8702665	DUST BOOT	1
10	8702666	MOUNTING BRACKET	1
11	8702667	HEX NUT	2
12	8702668	WASHER	2
13	8702669	THRUST WASHER	2
14	8702670	THRUST BEARING	1
15	8702671	SPRING ACTUATOR	1
16	8702672	ROTOR	1
17	8702673	BALL	3
18	8702674	SHAFT & STATOR ASSEMBLY	1
19		STATOR (NOT SOLD SEPARATELY)	1
20	8702675	SPRING	1
21	8702676	DUST BOOT	1
22	8702677	KEY	1
23	8702678	CASTING	1

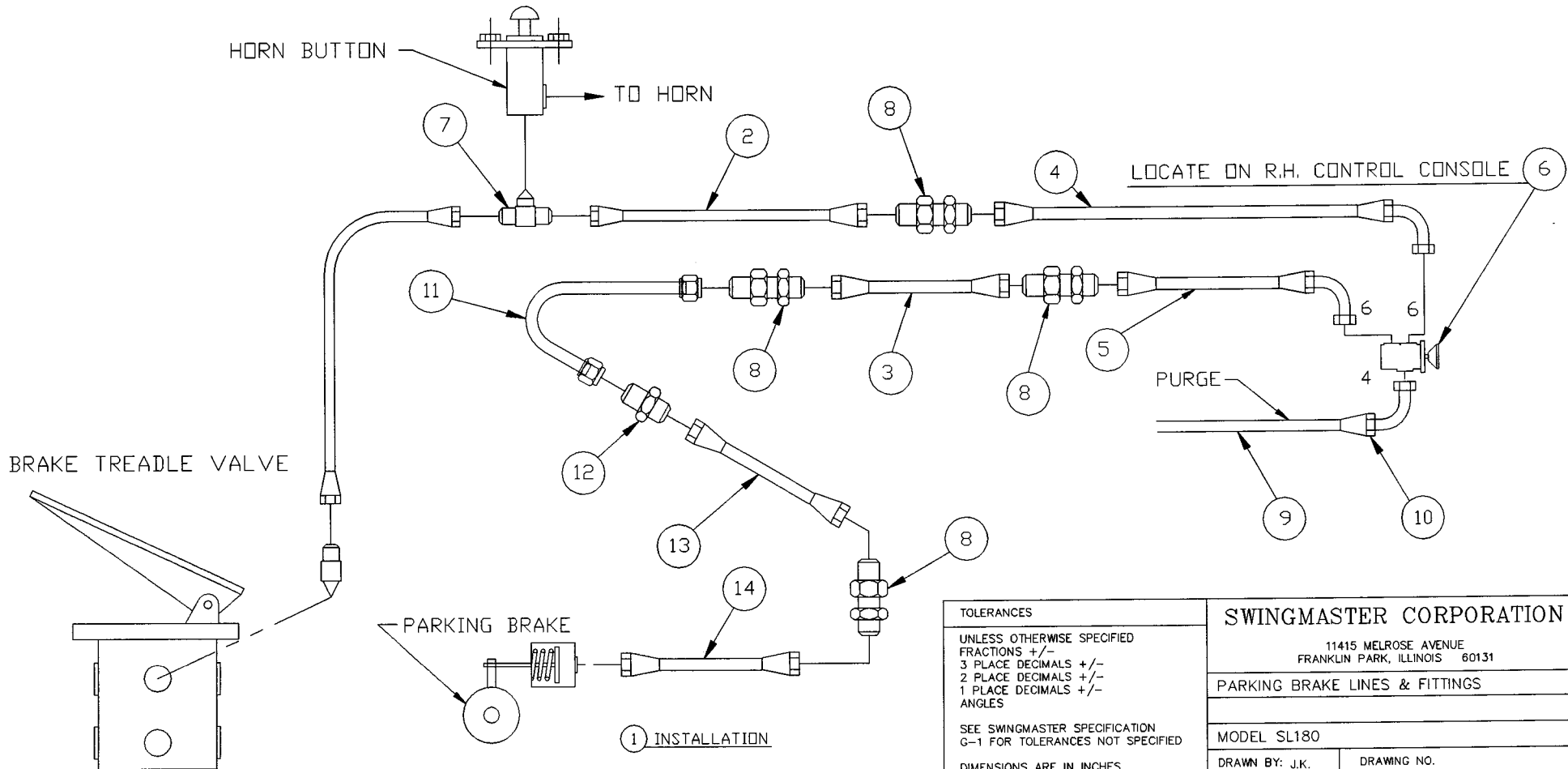

TOLERANCES

UNLESS OTHERWISE SPECIFIED
 FRACTIONS +/-
 3 PLACE DECIMALS +/-
 2 PLACE DECIMALS +/-
 1 PLACE DECIMALS +/-
 ANGLES

SEE SWINGMASTER SPECIFICATION
 G-1 FOR TOLERANCES NOT SPECIFIED

DIMENSIONS ARE IN INCHES
 DO NOT SCALE DRAWING
 SCALE: NONE

SWINGMASTER CORPORATION	
11415 MELROSE AVENUE FRANKLIN PARK, ILLINOIS 60131	
PARKING BRAKE LINES & FITTINGS	
MODEL SL180	
DRAWN BY: J.K.	DRAWING NO.
DATE: 7-28-98	H-418

MACHINE

SECTION

8

MODEL SL180 SWINGLOADER

PARKING BRAKE SYSTEM

ASSEMBLY
NUMBER

DESCRIPTION

1805808

PARKING BRAKE LINES AND FITTINGS

ITEM NO.	PART NUMBER	DESCRIPTION	QTY. USED
002	1801213	HOSE ASSEMBLY FC350 - 6	1.00
003	1805809	HOSE ASSEMBLY FC350-6	1.00
004	1805810	HOSE ASSEMBLY FC350-6	1.00
005	1805811	HOSE ASSEMBLY FC350-6	1.00
006	1805114	SEALCO AIR PRKG BRAKE CNTRL VALVE	1.00
007	1800917	MALE TEE 3/8 TUBE-3/8 TUBE-1/4 PIPE	1.00
008	1801033	3/8 TUBE STRAIGHT BULKHEAD UNION	4.00
009	1802726	FC-350-4 BULK HOSE/ (IN)	1.00
010	1800977	90 DEG SHORT ELBOW 1/4 UNI F-1503-4	1.00
011	1805787	TUBE ASSEMBLY	1.00
012	1804103	TUBE UNION - 3/8	1.00
013	1805812	HOSE ASSEMBLY FC350-6	1.00
014	1805813	HOSE ASSEMBLY FC350-6	1.00