



SECTION E
STEERING SYSTEM

SWINGMASTER CORPORATION

PARTS BOOK

MACHINE

SECTION

MODEL 361 SWINGLOADER

STEERING SYSTEM

DESCRIPTION

STEERING COLUMN INSTALLATION

ORBITROL ASSEMBLY

ORBITROL VALVE ASSEMBLY

STEERING SYSTEM CONTROL LINES AND FITTINGS

STEERING SELECTOR VALVE INSTALLATION

STEERING SELECTOR VALVE ASSEMBLY

STEERING SELECTOR VALVE INSTALLATION

STEERING SELECTOR VALVE ASSEMBLY

STEERING RELIEF VALVE INSTALLATION

STEERING RELIEF VALVE

STEERING CYLINDER INSTALLATION

STEERING CYLINDER

STEERING SELECTOR SWITCH INSTALLATION

SWINGMASTER CORPORATION

11415 MELROSE AVENUE

FRANKLIN PARK, ILLINOIS 60131

TELEPHONE: (847) 451-1224

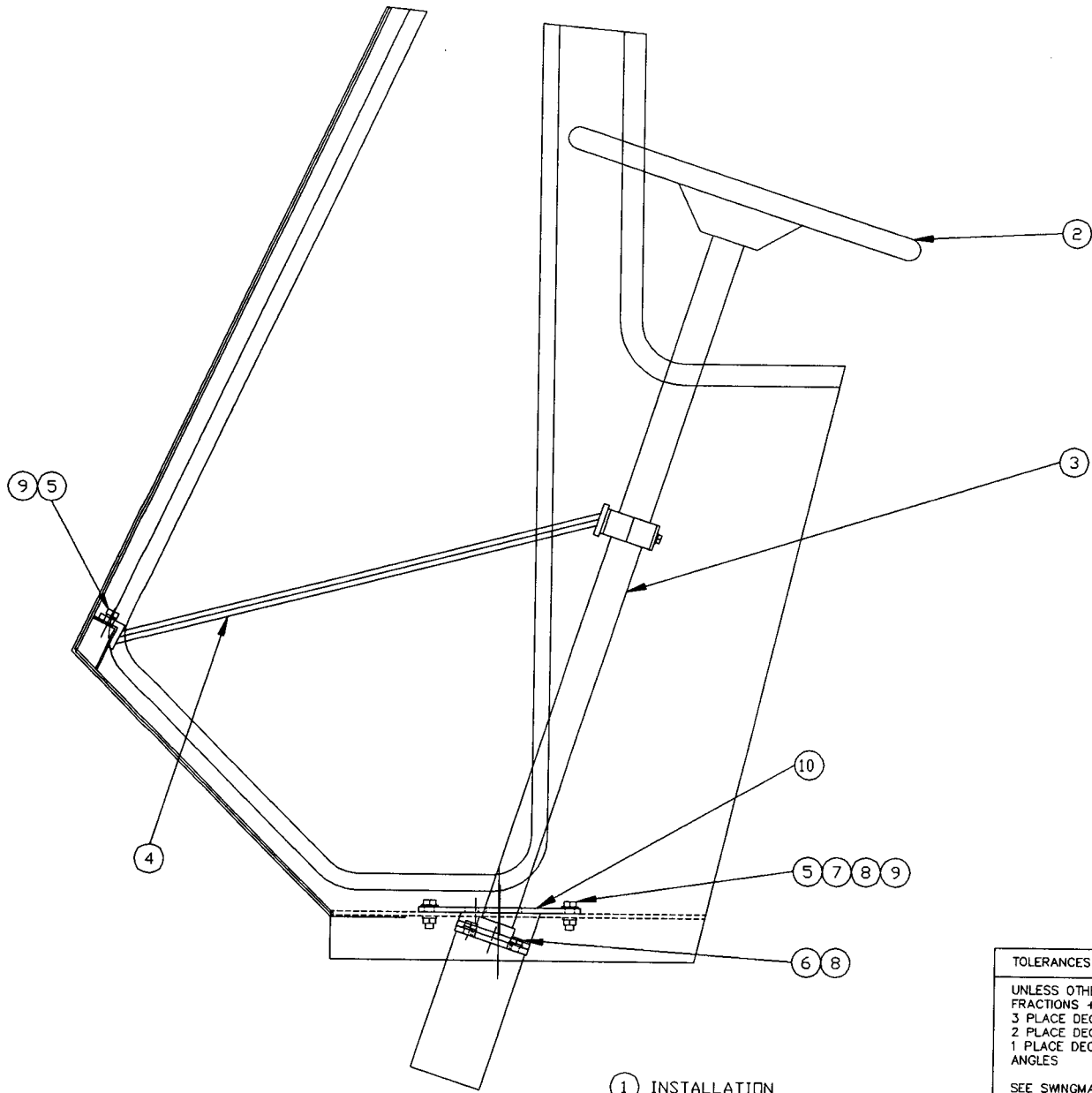

1 INSTALLATION

TOLERANCES
 UNLESS OTHERWISE SPECIFIED
 FRACTIONS +/-
 3 PLACE DECIMALS +/-
 2 PLACE DECIMALS +/-
 1 PLACE DECIMALS +/-
 ANGLES

SEE SWNGMASTER SPECIFICATION
 G-1 FOR TOLERANCES NOT SPECIFIED

DIMENSIONS ARE IN INCHES
 DO NOT SCALE DRAWING
 SCALE: 1=4

SWINGMASTER CORPORATION	
11415 MELROSE AVENUE FRANKLIN PARK, ILLINOIS 60131	
STEERING COLUMN INSTALLATION	
MODEL 361	
DRAWN BY: R.O.	DRAWING NO.
DATE: 11-17-88	C-126

SWINGMASTER CORPORATION

PARTS BOOK

MACHINE

SECTION

5

MODEL 361 SWINGLOADER -----

STEERING SYSTEM -----

ASSEMBLY
NUMBER

DESCRIPTION

1802153 -----

STEERING COLUMN INSTALLATION -----

ITEM PART

NO. NUMBER DESCRIPTION

QTY.
USED

2	1800239	STEERING WHEEL	1.00
3	1801194	ORBITROL ASSEMBLY	1.00
4	1802154	STEERING COLUMN BRACE	1.00
5	1800452	H.H.C.S. 3/8-16 X 1" LONG	6.00
6	1800454	H.H.C.S. 3/8-16 X 1 1/4" LONG	2.00
7	1800514	HEX NUT 3/8-16	4.00
8	1800552	3/8" FLAT WASHER	4.00
9	1800568	3/8" LOCK WASHER	8.00
10	1801195	STEERING GEAR MOUNTING BRACKET WELDMENT	1.00

SWINGMASTER CORPORATION

11415 MELROSE AVENUE

FRANKLIN PARK, ILLINOIS 60131

TELEPHONE: (847) 451-1224

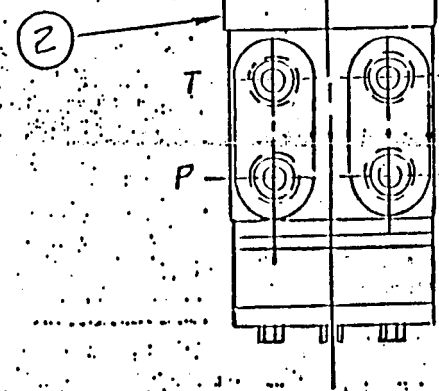
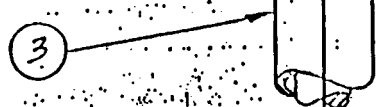
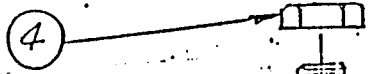
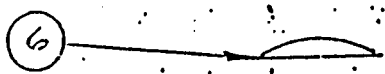

① ASS'Y

SWINGMASTER CORPORATION

PARTS BOOK

MACHINE

SECTION

5

MODEL 361 SWINGLOADER -----

STEERING SYSTEM -----

ASSEMBLY
NUMBER

DESCRIPTION

1801194

ORBITROL ASSEMBLY -----

ITEM PART

QTY.

NO. NUMBER DESCRIPTION

USED

2	1800233	ORBITROL VALVE	1.00
3	1800234	STEERING COLUMN	1.00
4	1800235	NUT (STEERING WHEEL)	1.00
6	1800237	STEERING WHEEL CAP	1.00

SWINGMASTER CORPORATION

11415 MELROSE AVENUE

FRANKLIN PARK, ILLINOIS 60131

TELEPHONE: (847) 451-1224

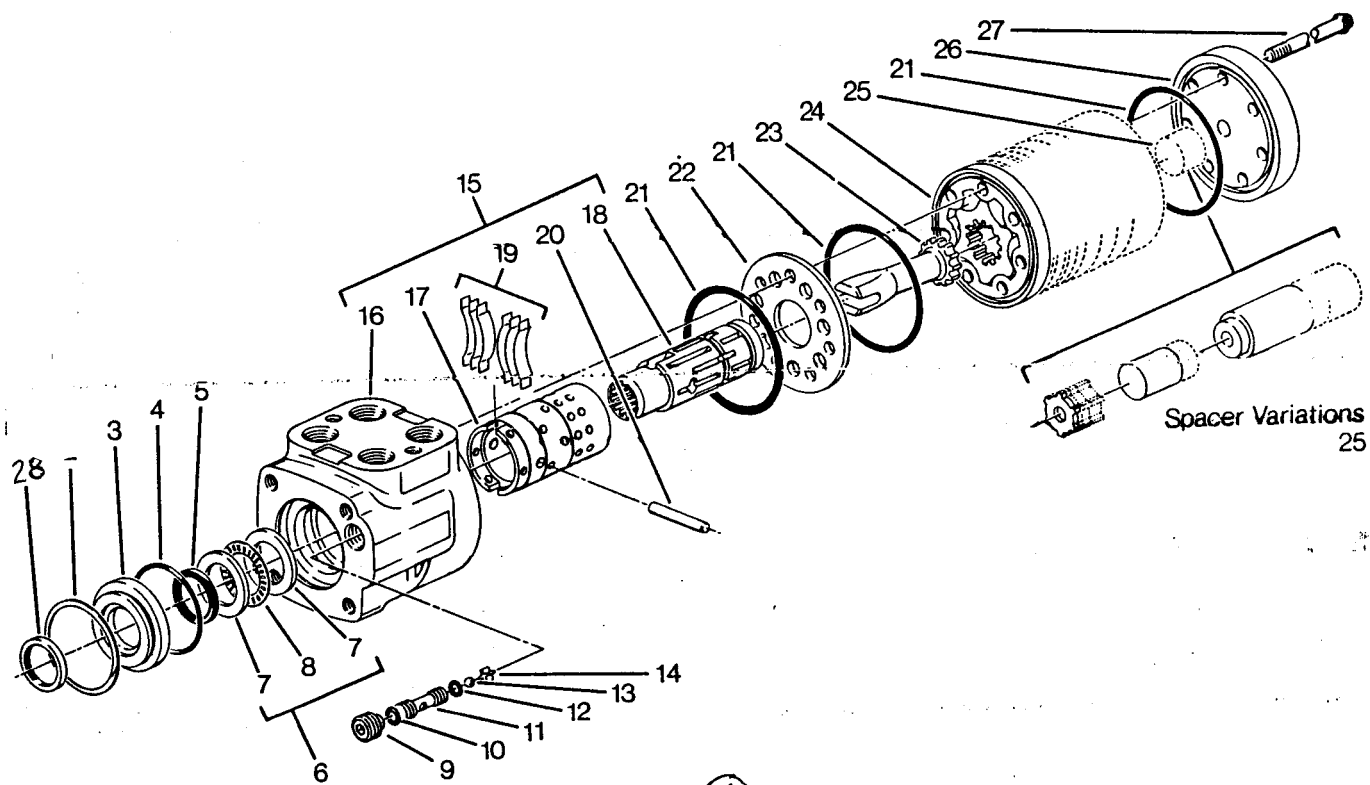

Spacer Variations
25

① ASSEMBLY

SWINGMASTER CORPORATION

PARTS BOOK

MACHINE

SECTION

5

MODEL 361 SWINGLOADER

STEERING SYSTEM

ASSEMBLY
NUMBER

DESCRIPTION

1800233

ORBITROL VALVE ASSEMBLY

ITEM NO.	PART NUMBER	DESCRIPTION	QTY. USED
2	8700646	RETAINING RING	1
3	8700647	SEAL GLAND BUSHING	1
4	8700648	SEAL	1
5	8700649	QUAD RING SEAL	1
6	8700650	NEEDLE BEARING KIT - INCLUDES ITEMS 7,8	1
7	8700651	BEARING RACE	2
8	8700652	NEEDLE THRUST BEARING	1
9	8700653	SET SCREW	1
10	8700654	SEAL	1
11	8700655	CHECK BALL SEAT	1
12	8700656	SEAL	1
13	8700657	CHECK BALL	1
14	8700658	CHECK BALL RETAINER	1
15	8700659	CONTROL PARTS ASSY - INCLUDES ITEMS 16-20	1
16		HOUSING	1
17		CONTROL SLEEVE	1
18		CONTROL SPOOL	1
19	8700660	CENTERING SPRING	6
20	8700661	CENTERING PIN	1
21	8700662	SEAL	3
22	8700663	SPACER PLATE	1
23	8700664	DRIVE	1
24	8700665	GEROTOR	1
25	8700666	SPACER	1
26	8700667	END CAP	1
27	8700668	CAP SCREW	7
28	8700669	SEAL	1
	8700670	SEAL KIT - INCLUDES ITEMS 4,5,10,12,21,28	1

SWINGMASTER CORPORATION
11415 MELROSE AVENUE
FRANKLIN PARK, ILLINOIS 60131

TELEPHONE: (847) 451-1224

← FRONT OF MACHINE

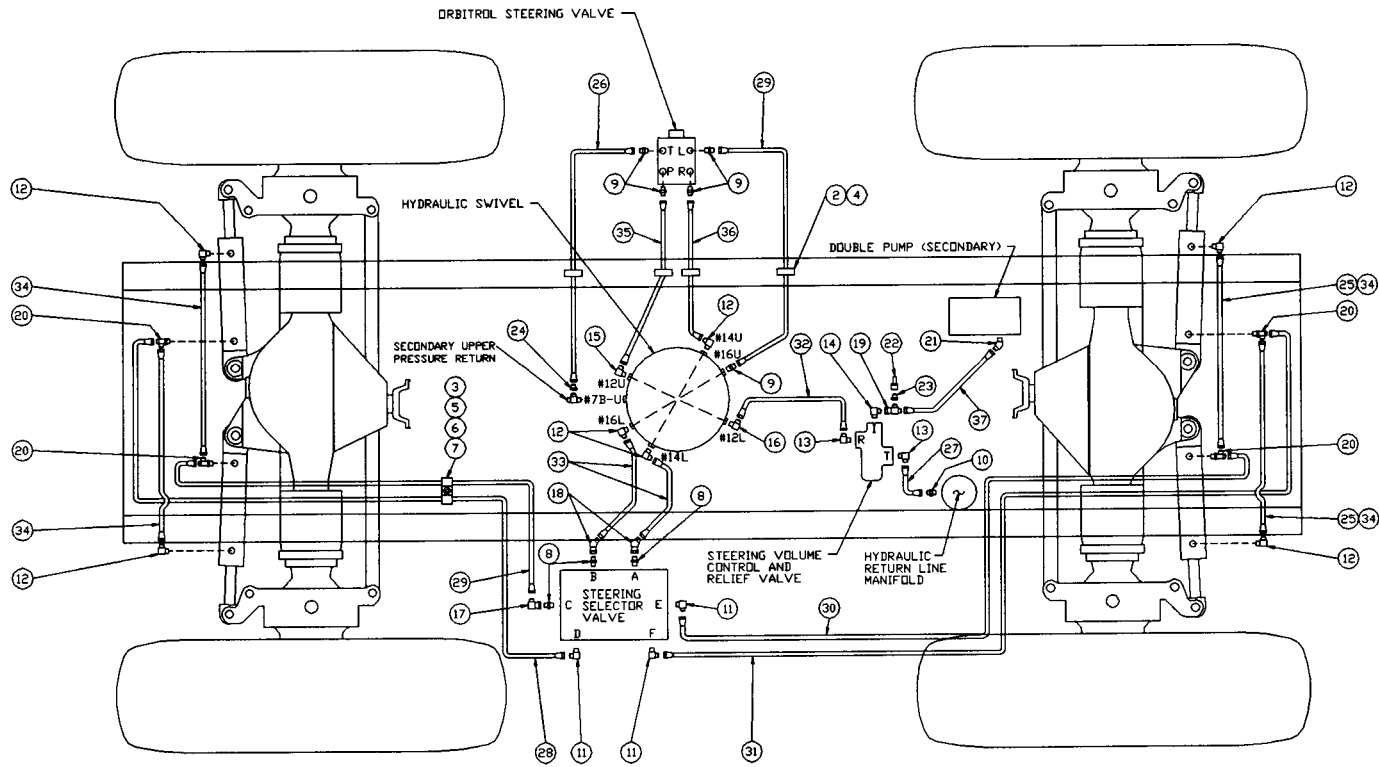

① INSTALLATION

TOLERANCES UNLESS OTHERWISE SPECIFIED FRACTIONS +/- 3 PLACE DECIMALS +/- 2 PLACE DECIMALS +/- 1 PLACE DECIMALS +/- ANGLES	SWINGMASTER CORPORATION 11415 MELROSE AVENUE FRANKLIN PARK, ILLINOIS 60131	
	STEERING CONTROL HYDRAULIC LINES & FITTINGS	
SEE SWINGMASTER SPECIFICATION G-1 FOR TOLERANCES NOT SPECIFIED	MODEL 361	
DIMENSIONS ARE IN INCHES DO NOT SCALE DRAWING SCALE: 1/4" = 1"	DRAWN BY: R.O. DATE: 12-15-88	DRAWING NO. D-237

MACHINE

SECTION

5

MODEL 361 SWINGLOADER

STEERING SYSTEM

ASSEMBLY

NUMBER

DESCRIPTION

1802309STEERING SYSTEM CONTROL LINES & FITTINGS

ITEM NO.	PART NUMBER	DESCRIPTION	QTY. USED
2	1800228	HOSE CLAMP - 1"	4.00
3	1800451	H.H.C.S. 3/8-16 X 3/4" LONG	1.00
4	1802492	H.H.C.S. 1/4-20 X 3" LONG	4.00
5	1800514	HEX NUT 3/8-16	1.00
6	1800568	3/8" LOCK WASHER	1.00
7	1800743	1 1/16" DIAMETER CLAMP	2.00
8	1800763	STRAIGHT MALE 3/8 0-RING TO 1/2 TUBE	3.00
9	1800765	STRAIGHT MALE 1/2 0-RING TO 1/2 TUBE	5.00
10	1800769	STRAIGHT MALE 3/4 0-RING TO 5/8 TUBE	1.00
11	1800795	90 DEG MALE ELBOW 3/8 0-RING TO 1/2 TUBE	3.00
12	1800796	90 DEG MALE ELBOW 1/2 0-RING TO 1/2 TUBE	7.00
13	1800798	90 DEG MALE ELBOW 5/8 0-RING TO 5/8 TUBE	2.00
14	1800799	90 DEG MALE ELBOW 5/8 0-RING TO 3/4 TUBE	1.00
15	1800800	90 DEG MALE ELBOW 3/4 0-RING TO 1/2 TUBE	1.00
16	1802358	90 DEG MALE ELBOW 3/4 0-RING TO 5/8 TUBE	1.00
17	1800853	90 DEG TUBE ELBOW 1/2 M TO 1/2 F SWIVEL	1.00
18	1800855	45 DEG TUBE ELBOW 1/2 M TO 1/2 F SWIVEL	2.00
19	1800861	3/4 TUBE RUN TEE M-F SWIVEL-M	1.00
20	1802493	MALE RUN TEE 1/2 0-RING TO 1/2 TUBE	4.00
21	1802331	45 DEG MALE ELBOW 3/4 TUBE TO 3/4 0-RING	1.00
22	1801668	PRESSURE SENSING COUPLING - 3/8 TUBE	1.00
23	1802494	STRAIGHT TUBE ADAPTER 3/8 TO 3/4	1.00
24	1802380	STRAIGHT TUBE ADAPTER 1/2-M TO 3/4-F	1.00
25	1802495	PROTECTIVE SLEEVE - 3/4" I.D. / (FT)	4.00
26	1801197	HOSE ASSEMBLY 1503 - 8	1.00
27	1802496	HOSE ASSEMBLY 1503-10	1.00
28	1802497	HOSE ASSEMBLY 2781-8	1.00
29	1802498	HOSE ASSEMBLY 2781-8	2.00
30	1802499	HOSE ASSEMBLY 2781-8	1.00
31	1802500	HOSE ASSEMBLY 2781-8	1.00
32	1802501	HOSE ASSEMBLY 2781-10	1.00

SWINGMASTER CORPORATION

11415 MELROSE AVENUE

FRANKLIN PARK, ILLINOIS 60131

TELEPHONE: (847) 451-1224

← FRONT OF MACHINE

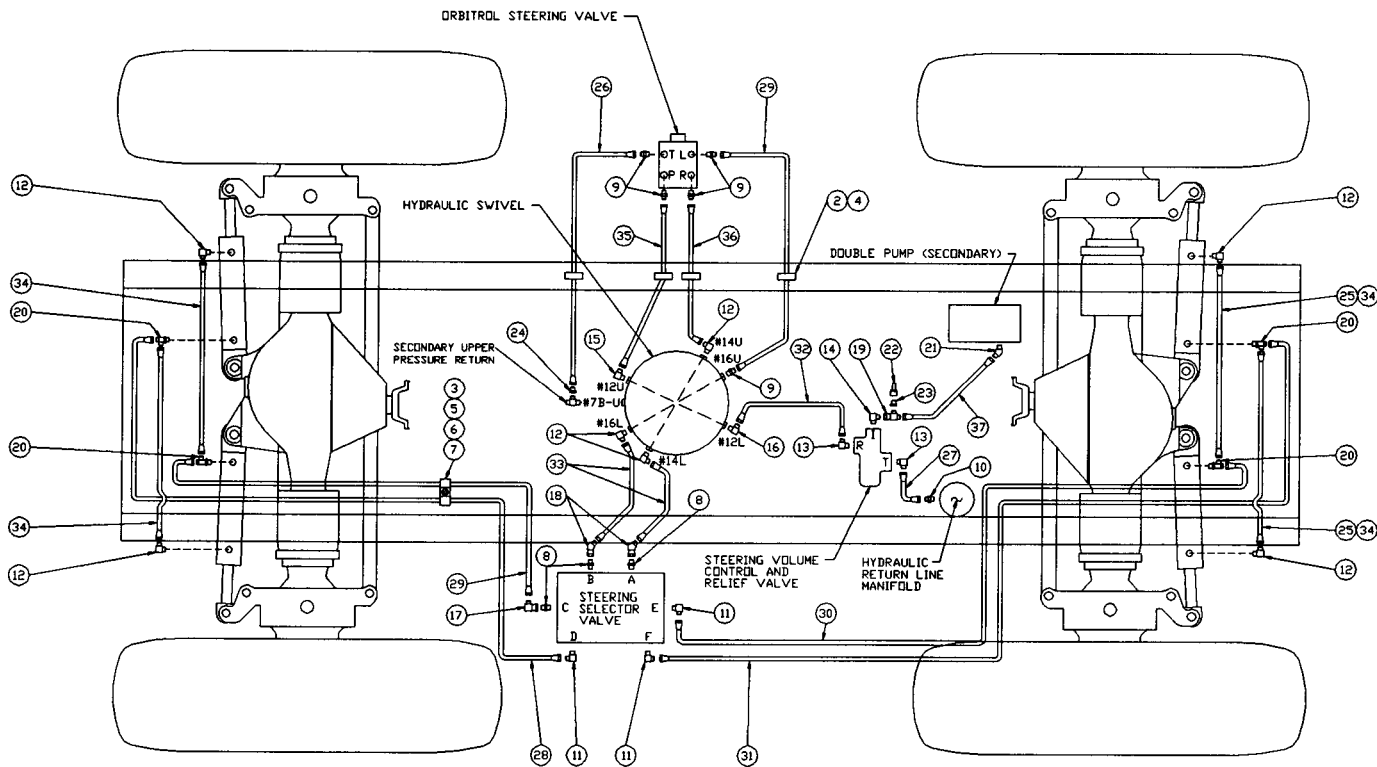

① INSTALLATION

<p>TOLERANCES</p> <p>UNLESS OTHERWISE SPECIFIED</p> <p>FRACTIONS +/-</p> <p>3 PLACE DECIMALS +/-</p> <p>2 PLACE DECIMALS +/-</p> <p>1 PLACE DECIMALS +/-</p> <p>ANGLES</p> <p>SEE SWINGMASTER SPECIFICATION</p> <p>G-1 FOR TOLERANCES NOT SPECIFIED</p> <p>DIMENSIONS ARE IN INCHES</p> <p>DO NOT SCALE DRAWING</p> <p>SCALE 1/4"=1'-0"</p>	<p>SWINGMASTER CORPORATION</p> <p>11415 MELROSE AVENUE</p> <p>FRANKLIN PARK, ILLINOIS 60131</p>	
	<p>STEERING CONTROL HYDRAULIC LINES & FITTINGS</p>	
	<p>MODEL 361</p>	<p>DRAWING NO.</p>
	<p>DRAWN BY: R.O.</p>	<p>DATE: 12-15-88</p>
		<p>D-237</p>

SWINGMASTER CORPORATION

PARTS BOOK

MACHINE

SECTION

5

MODEL 361 SWINGLOADER -----

STEERING SYSTEM -----

ASSEMBLY
NUMBER

DESCRIPTION

1802309 -----

STEERING SYSTEM CONTROL LINES & FITTINGS -----

ITEM PART

NO. NUMBER DESCRIPTION

QTY.

USED

33	1802344	HOSE ASSEMBLY 2781-8	2.00
34	1802502	HOSE ASSEMBLY 2781-8	4.00
35	1802503	HOSE ASSEMBLY 2781-8	1.00
36	1802504	HOSE ASSEMBLY 2781-8	1.00
37	1802329	HOSE ASSEMBLY 2781-12	1.00

SWINGMASTER CORPORATION

11415 MELROSE AVENUE

FRANKLIN PARK, ILLINOIS 60131

TELEPHONE: (847) 451-1224

PORT	FUNCTION
A	PRESSURE IN - RIGHT TURN
B	PRESSURE IN - LEFT TURN
C	PRESSURE OUT - FRONT LEFT TURN
D	PRESSURE OUT - FRONT RIGHT TURN
E	PRESSURE OUT - REAR LEFT TURN
F	PRESSURE OUT - REAR RIGHT TURN

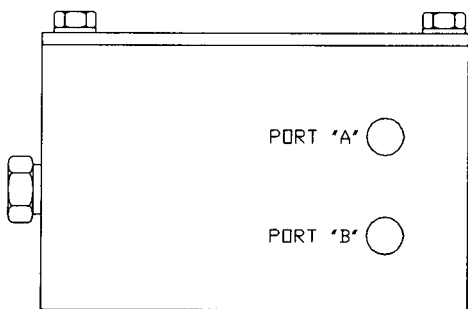
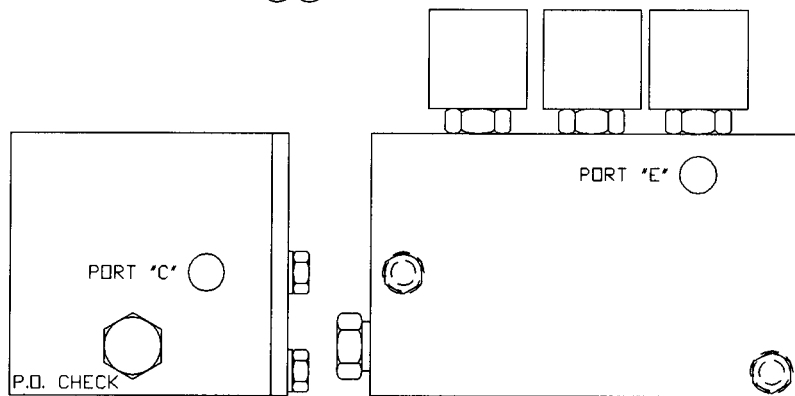
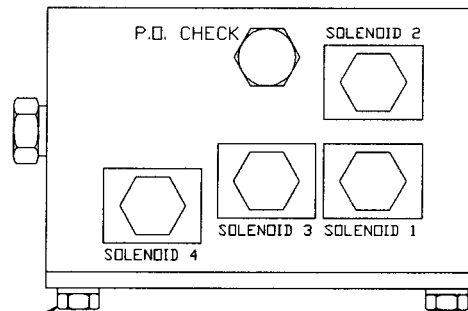

ALL PORTS 9/16-18 S.A.E. O-RING BOSS (-6)

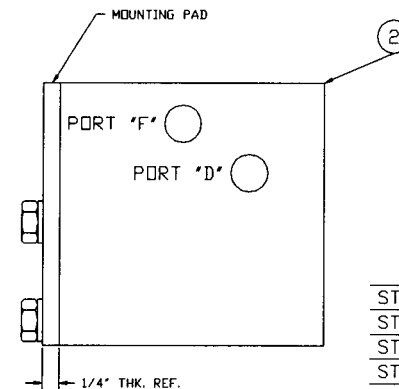

ELECTRICAL FUNCTIONS

	SOL(1)	SOL(2)	SOL(3)	SOL(4)
STEER FRONT	0	0	0	0
STEER REAR	X	X	0	0
STEER CRAB	0	0	X	0
STEER FOUR	0	0	0	X

X = ENERGIZED
0 = DEENERGIZED

1 INSTALLATION

TOLERANCES	SWINGMASTER CORPORATION	
UNLESS OTHERWISE SPECIFIED FRACTIONS +/- 3 PLACE DECIMALS +/- 2 PLACE DECIMALS +/- 1 PLACE DECIMALS +/- ANGLES	11415 MELROSE AVENUE FRANKLIN PARK, ILLINOIS 60131	
SEE SWINGMASTER SPECIFICATION G-1 FOR TOLERANCES NOT SPECIFIED	STEERING SELECTOR VALVE INSTALLATION	
DIMENSIONS ARE IN INCHES DO NOT SCALE DRAWING SCALE 1=2	DRAWN BY: R.O. DATE: 1-24-89	DRAWING NO. H-184

MACHINE

SECTION

5

MODEL 361 SWINGLOADER

STEERING SYSTEM

SERIAL NUMBERS

88361L0001 TO 89361L0003 AND
90361L0006 TO CURRENT

ASSEMBLY

NUMBER

DESCRIPTION

1802475

STEERING_SELECTOR_VALVE_INSTALLATION

ITEM PART

QTY.

NO. NUMBER DESCRIPTION

USED

2	1800248	STEERING SELECTOR VALVE	1.00
3	1800454	H.H.C.S.3/8-16 X 1 1/4" LONG	2.00
4	1800568	3/8" LOCK WASHER	2.00

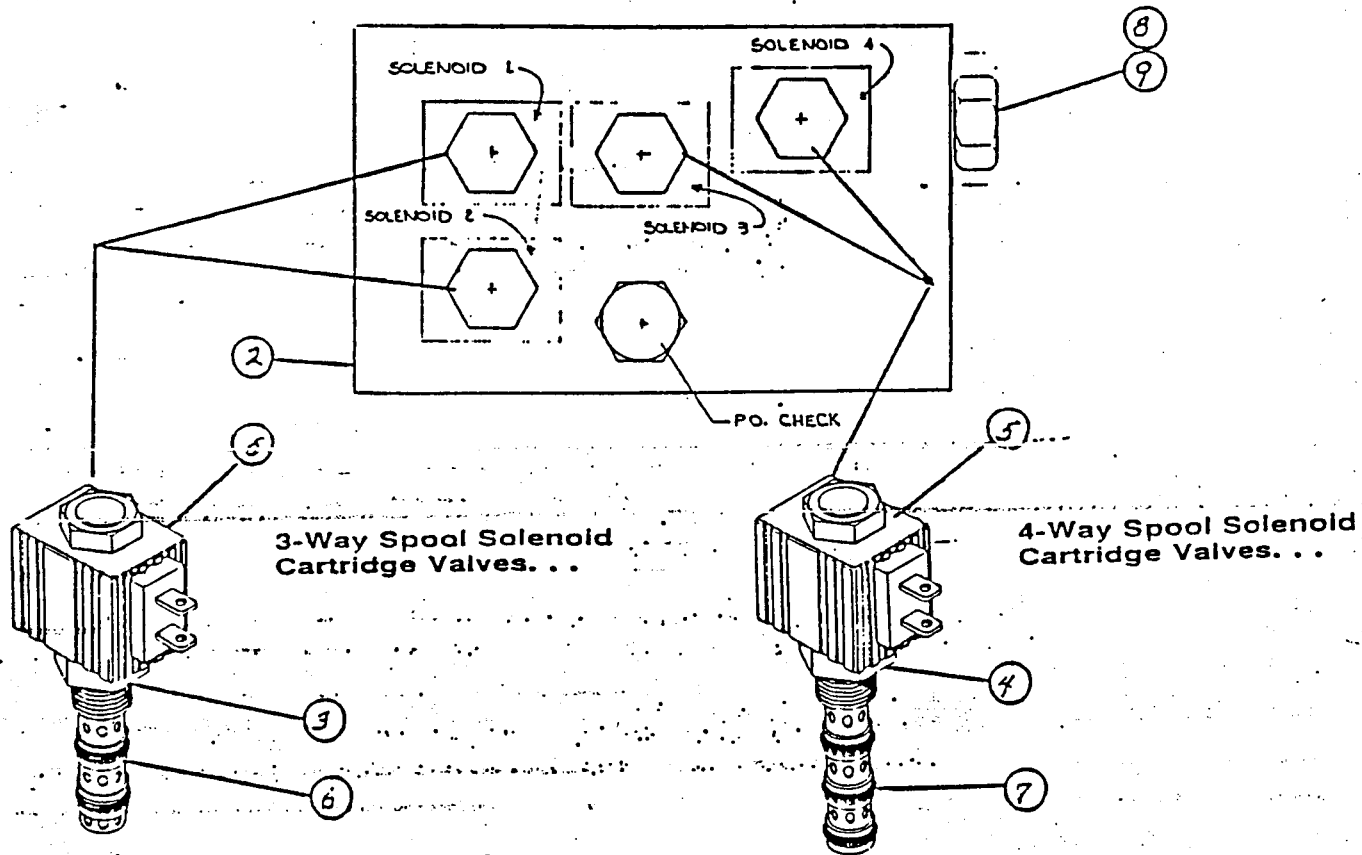

1 Installation

MACHINE	SECTION	5
-----	-----	-----
MODEL 361 SWINGLOADER	STEERING SYSTEM	
SERIAL NUMBERS	-----	
88361L0001 TO 89361L0003 AND		
90361L0006 TO CURRENT		

ASSEMBLY	DESCRIPTION
NUMBER	-----
1800248	STEERING_SELECTOR_VALVE_ASSEMBLY

ITEM PART	QTY.
NO. NUMBER DESCRIPTION	USED
-----	-----
2 8700898 ALUMINUM BLOCK	1
3 8700899 3 WAY SPOOL CARTRIDGE VALVE WITHOUT COIL	2
4 8700900 4 WAY SPOOL CARTRIDGE VALVE WITHOUT COIL	2
5 8700901 COIL	4
6 8700902 SEAL KIT FOR ITEM 3	2
7 8700903 SEAL KIT FOR ITEM 4	2
8 8700904 CHECK VALVE	1
9 8700905 SEAL KIT FOR ITEM 8	1
-----	-----

PORT	FUNCTION
A	PRESSURE IN - RIGHT TURN
B	PRESSURE IN - LEFT TURN
C	PRESSURE OUT - FRONT LEFT TURN
D	PRESSURE OUT - FRONT RIGHT TURN
E	PRESSURE OUT - REAR LEFT TURN
F	PRESSURE OUT - REAR RIGHT TURN

ALL PORTS 9/16-18 S.A.E. O-RING BOSS (-6)

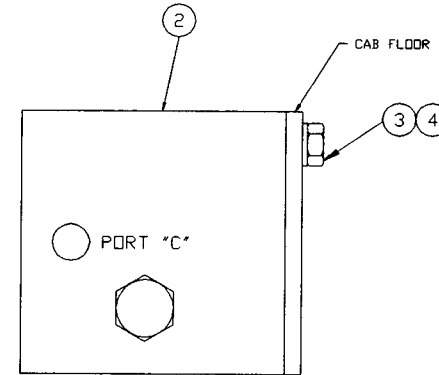
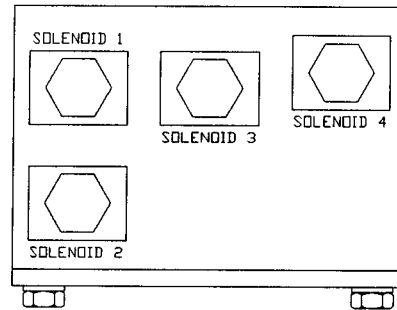
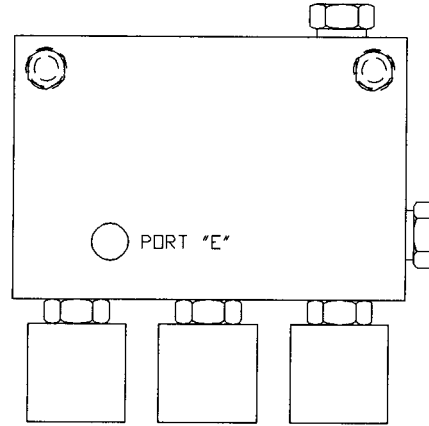
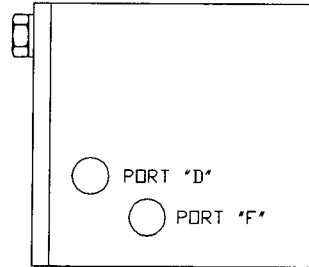
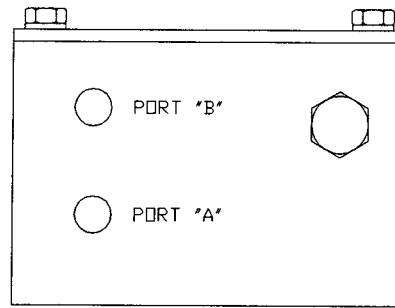

ELECTRICAL FUNCTIONS

	SOL(1)	SOL(2)	SOL(3)	SOL(4)
STEER FRONT	0	0	0	0
STEER REAR	X	X	0	0
STEER CRAB	0	0	X	0
STEER FOUR	0	0	0	X

X = ENERGIZED
0 = DEENERGIZED

① INSTALLATION

TOLERANCES	SWINGMASTER CORPORATION	
UNLESS OTHERWISE SPECIFIED FRACTIONS +/- 3 PLACE DECIMALS +/- 2 PLACE DECIMALS +/- 1 PLACE DECIMALS +/- ANGLES SEE SWINGMASTER SPECIFICATION G-1 FOR TOLERANCES NOT SPECIFIED DIMENSIONS ARE IN INCHES DO NOT SCALE DRAWING SCALE: 1=2	11415 MELROSE AVENUE FRANKLIN PARK, ILLINOIS 60131	
	STEERING SELECTOR VALVE INSTALLATION	
	MODEL 182	
DRAWN BY: R.O.	DRAWING NO.	
DATE: 6-5-90	H1-184	

SWINGMASTER CORPORATION

PARTS BOOK

MACHINE

SECTION

5

MODEL 361 SWINGLOADER
SERIAL NUMBERS
90361L0004 TO 90361L0005

STEERING SYSTEM

ASSEMBLY
NUMBER

DESCRIPTION

1803625

STEERING_SELECTOR_VALVE_INSTALLATION_ _ _

ITEM PART

QTY.

NO. NUMBER DESCRIPTION

USED

2	1803618	STEERING SELECTOR VALVE	1.00
3	1800454	H.H.C.S. 3/8-16 X 1 1/4" LONG	2.00
4	1800568	3/8" LOCK WASHER	2.00

SWINGMASTER CORPORATION

11415 MELROSE AVENUE

FRANKLIN PARK, ILLINOIS 60131

TELEPHONE: (847) 451-1224

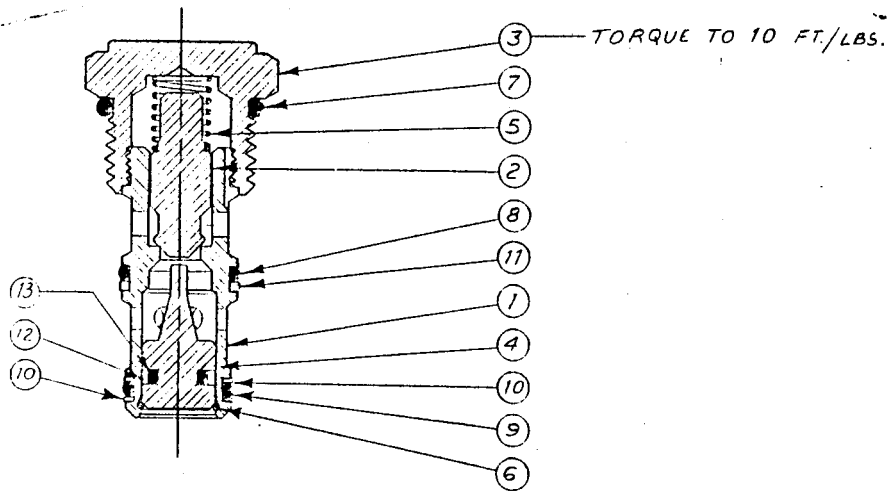

11 ASSEMBLY

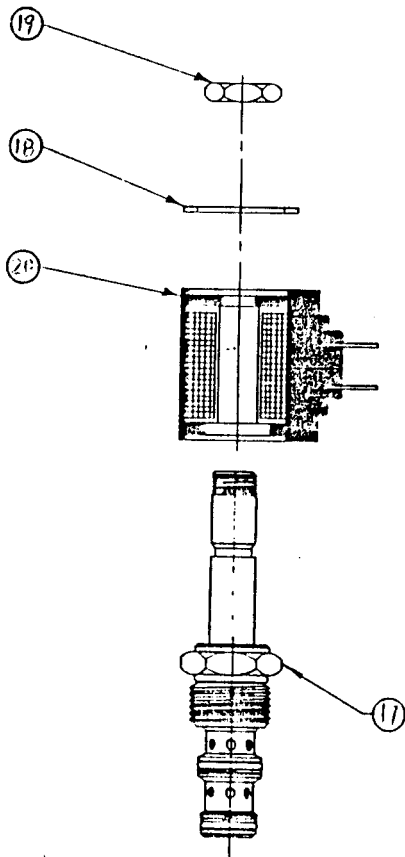

15 ASSEMBLY

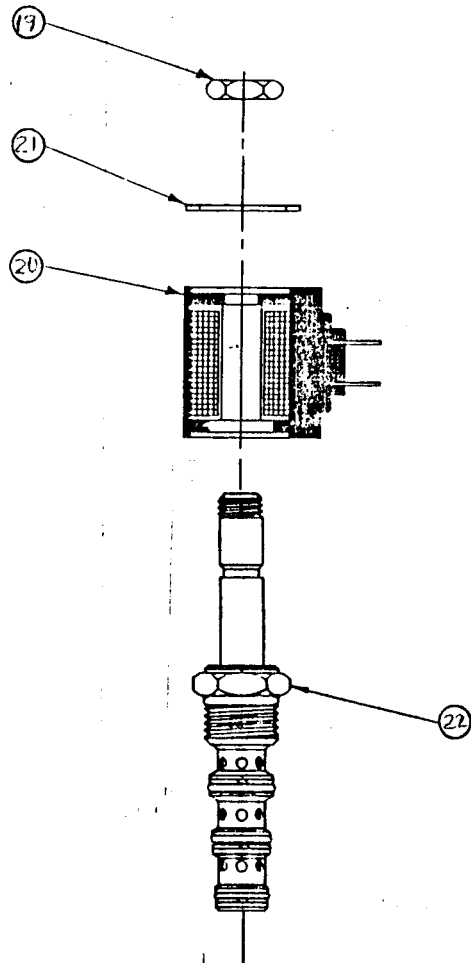

23 ASSEMBLY

MACHINE	SECTION	5
-----	-----	-----
MODEL 361 SWINGLOADER	STEERING SYSTEM	
FOR SERIAL NUMBERS	-----	
90361L0004 TO 90361L0005		

ASSEMBLY	-----
NUMBER	DESCRIPTION
-----	-----
1803618	STEERING_SELECTOR_VALVE_ASSEMBLY

ITEM PART	QTY.
NO. NUMBER DESCRIPTION	USED

1	1
2	1
3	1
4	1
5	1
6	1
7	1
8	1
9	1
10	2
11	1
12	1
13	1
14	2
15	2
16	3
17	2
18	2
19	4
20	4
21	2
22	2
23	2
24	2
8703250	1

ALL PORTS 7/8-14 S.A.E. O-RING BOSS (-10)

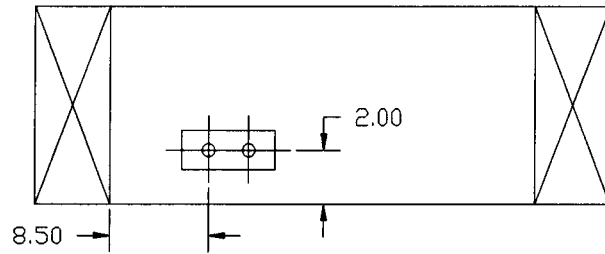
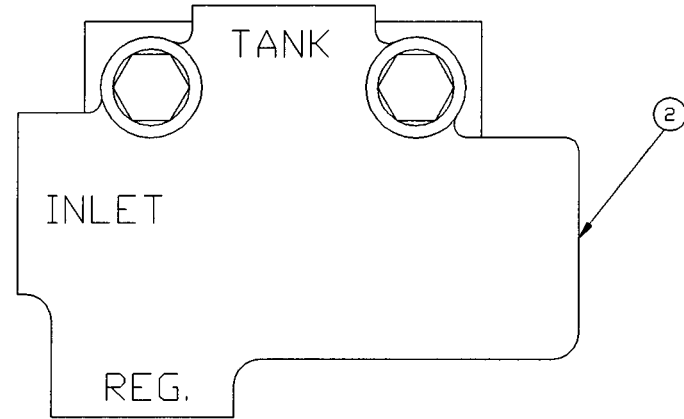
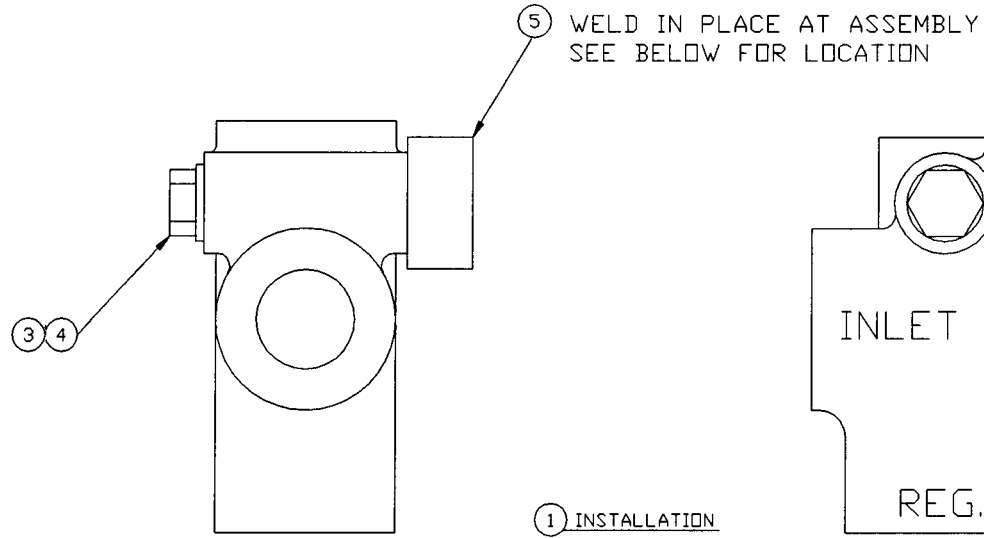

MAIN FRAME SECTION VIEW

1	1-3-91
REV. NO.	DATE

TOLERANCES		SWINGMASTER CORPORATION	
UNLESS OTHERWISE SPECIFIED		11415 MELROSE AVENUE	
FRACTIONS +/-		FRANKLIN PARK, ILLINOIS 60131	
3 PLACE DECIMALS +/-		STEERING RELIEF VALVE INSTALLATION	
2 PLACE DECIMALS +/-		MODEL 361	
1 PLACE DECIMALS +/-		DRAWN BY: R.O.	
ANGLES		DATE: 1-23-89	
SEE SWINGMASTER SPECIFICATION		DRAWING NO.	
G-1 FOR TOLERANCES NOT SPECIFIED		H-183	
DIMENSIONS ARE IN INCHES			
DO NOT SCALE DRAWING			
SCALE:			

SWINGMASTER CORPORATION

PARTS BOOK

MACHINE

SECTION

5

MODEL 361 SWINGLOADER -----

STEERING SYSTEM -----

ASSEMBLY
NUMBER

DESCRIPTION

1802473

STEERING RELIEF VALVE INSTALLATION -----

ITEM PART

NO. NUMBER DESCRIPTION

QTY.

USED

2 1802474 STEERING RELIEF VALVE - 2500 PSI 1.00
3 1800447 H.H.C.S. 5/16-18 X 2" LONG 2.00
4 1800074 5/16" LOCK WASHER 2.00
5 1803667 BAR 1.00

SWINGMASTER CORPORATION
11415 MELROSE AVENUE

FRANKLIN PARK, ILLINOIS 60131

TELEPHONE: (847) 451-1224

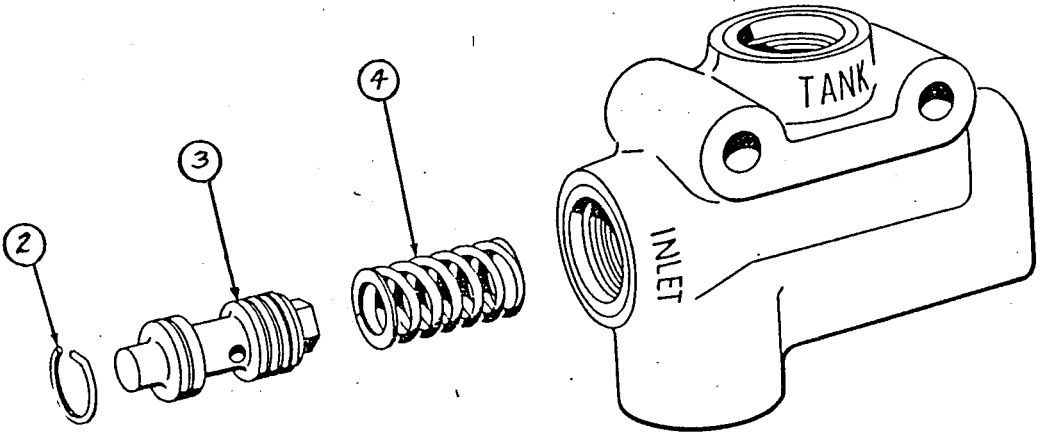

① ASSEMBLY

SWINGMASTER CORPORATION

PARTS BOOK

MACHINE

SECTION

5

MODEL 361 SWINGLOADER

STEERING SYSTEM

ASSEMBLY
NUMBER

DESCRIPTION

1802474

STEERING RELIEF VALVE

ITEM PART

QTY.

NO. - NUMBER - DESCRIPTION -

USED -

2 8701149 SNAP RING

1

3 8702308 CONTROL VALVE SUB ASSEMBLY

1

4 - - - - ~~8701151 SPRING~~ - - - -

~~1~~ - - - -

SWINGMASTER CORPORATION

11415 MELROSE AVENUE

FRANKLIN PARK, ILLINOIS 60131

TELEPHONE: (847) 451-1224

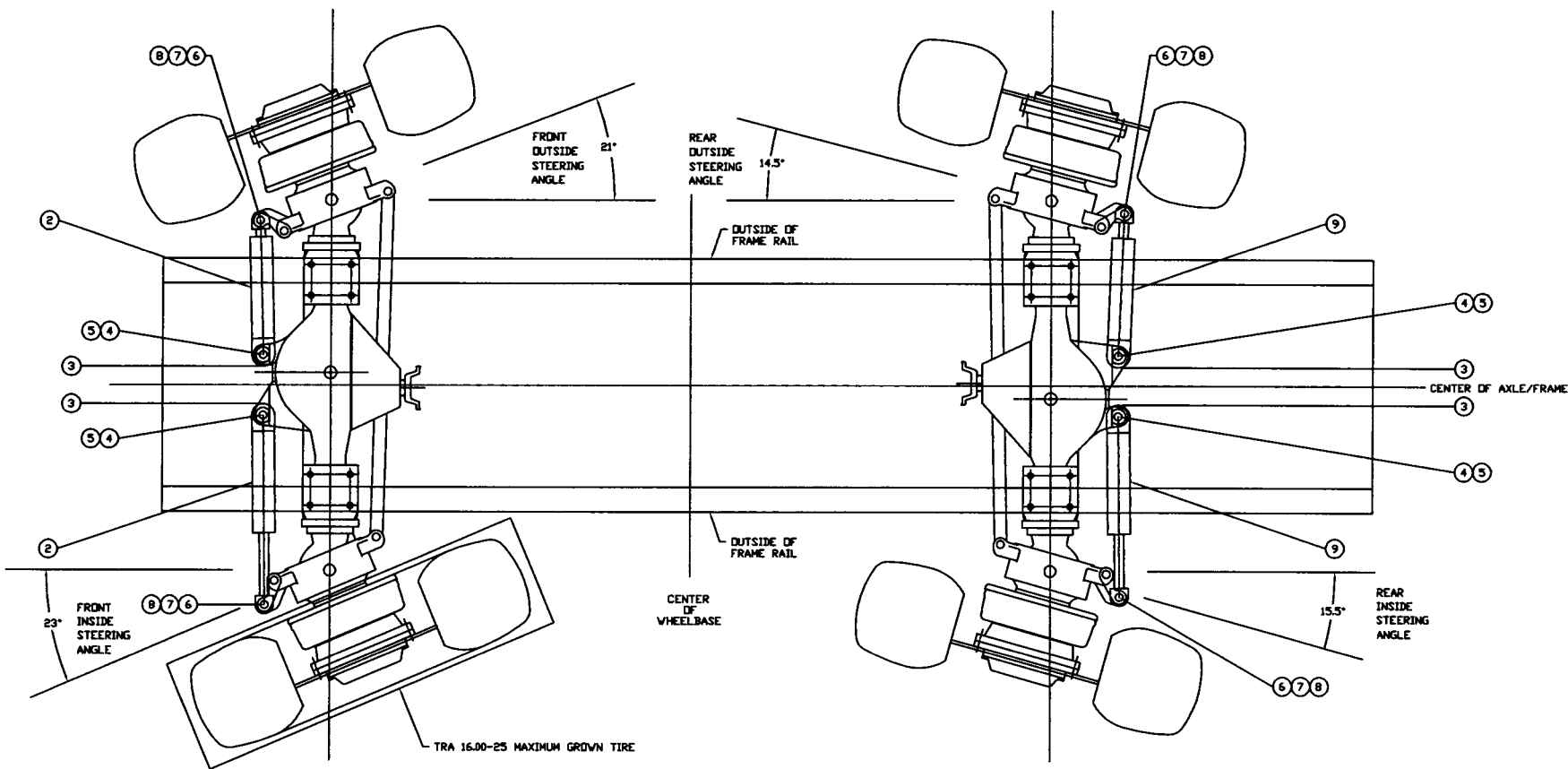

DRAWING SHOWN WITH
 16.00-25 TIRE
 2 1/16" DISH WHEEL

TOLERANCES
 UNLESS OTHERWISE SPECIFIED
 FRACTIONS +/-
 3 PLACE DECIMALS +/-
 2 PLACE DECIMALS +/-
 1 PLACE DECIMALS +/-
 ANGLES

SEE SWINGMASTER SPECIFICATION
 0-1 FOR TOLERANCES NOT SPECIFIED

DIMENSIONS ARE IN INCHES
 DO NOT SCALE DRAWING
 SCALE: 1=9

SWINGMASTER CORPORATION
 11415 MELROSE AVENUE
 FRANKLIN PARK, ILLINOIS 60131

STEERING CYLINDER INSTALLATION

MODEL 361

DRAWN BY: R.O. DATE: 8-4-88

DRAWING NO. **D-171**

REVISION
 1

SWINGMASTER CORPORATION

PARTS BOOK

MACHINE

SECTION

5

MODEL 361 SWINGLOADER

STEERING SYSTEM

ASSEMBLY
NUMBER

DESCRIPTION

1801987

STEERING CYLINDER INSTALLATION

ITEM PART

NO. NUMBER DESCRIPTION

QTY.

USED

2	1801988	STEERING CYLINDER - 10.00" STROKE	2.00
3	1800059	65 DEG 1/8" PIPE-M GREASE FITTING	4.00
4	1801989	PIN	4.00
5	1801990	COTTER PIN 1/4" DIA. X 1 3/4" LONG	4.00
6	1800005	PIN	4.00
7	1800007	COTTER PIN 1/4 X 2" LONG	4.00
8	1800663	STRAIGHT 1/8" PIPE-M GREASE FITTING	4.00
9	1802905	STEERING CYLINDER - 6.19" STROKE	2.00

SWINGMASTER CORPORATION
11415 MELROSE AVENUE

FRANKLIN PARK, ILLINOIS 60131

TELEPHONE: (847) 451-1224

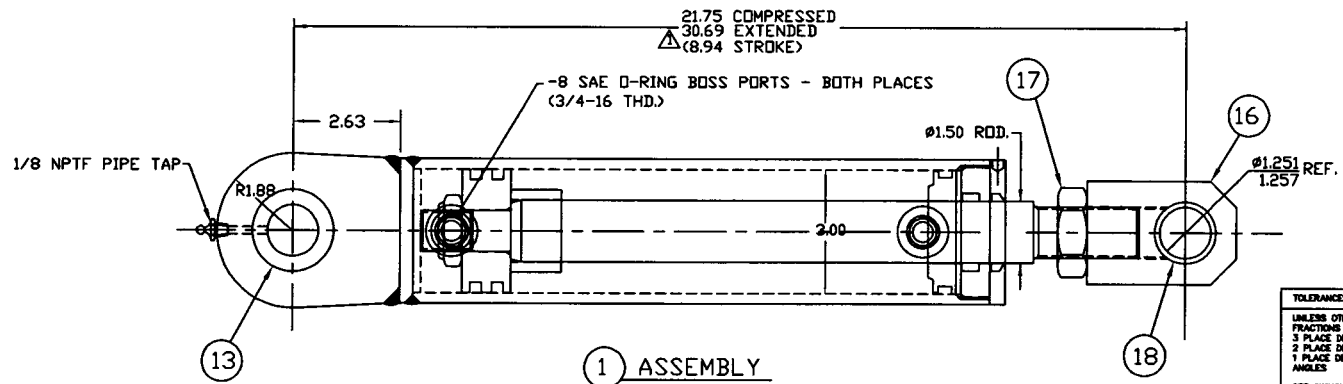
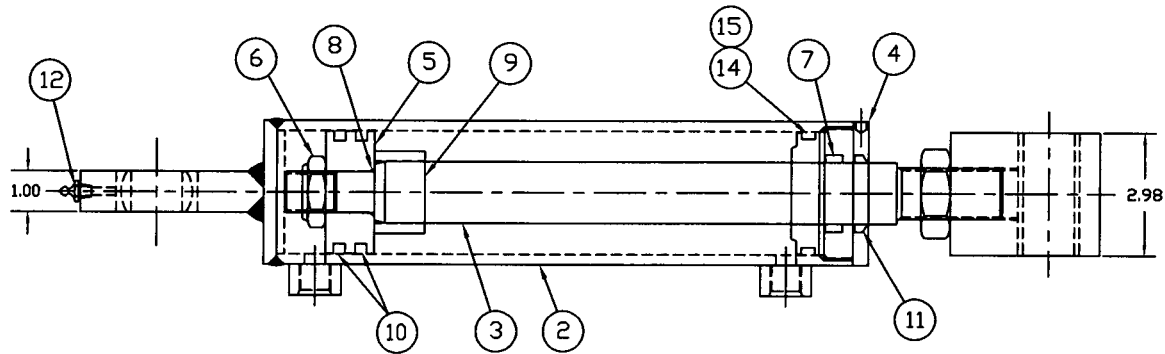

WORKING PRESSURE = 2500 PSI
PRIME PAINT

TOLERANCES		SWINGMASTER CORPORATION	
UNLESS OTHERWISE SPECIFIED		11410 MELROSE AVENUE	
FRACTIONS +/-		FRANKLIN PARK, ILLINOIS 60131	
3 PLACE DECIMALS +/-		STEERING CYLINDER	
2 PLACE DECIMALS +/-		MODEL 361 & SL180	
1 PLACE DECIMALS +/-			
ANGLES			
SEE SWINGMASTER SPECIFICATION		DRAWN BY: J.K.	
0-1 FOR TOLERANCES NOT SPECIFIED		DATE: 10-10-05	
DIMENSIONS ARE IN INCHES		DRAWING NO.	
DO NOT SCALE DRAWING		D-169	
SCALE: 2=3			

REV	DATE	DESCRIPTION	ENG. NO.	BY
△	10-23-05	B/M ADDED.	2005005	J.K.

MACHINE

SECTION

5

MODEL 361 SWINGLOADER

STEERING SYSTEM

ASSEMBLY
NUMBER

DESCRIPTION

1801988 STEERING CYLINDER

ITEM NO.	PART NUMBER	DESCRIPTION	QTY USED
2	1806835	CASE WELDMENT	1
3	1806836	CYLINDER ROD	1
4	1806837	CAP	1
5	1806838	PISTON	1
6	1806839	LOCKNUT	1
7	1806610	ROD SEAL	1
8	1806604	"0" RING	1
9	1806840	SPACER	1
10	1806611	PISTON SEAL	2
11	1806612	WIPER	1
12	1800663	STRAIGHT 1/8" MALE-PIPE GREASE	1
13	1806176	SPHERICAL BUSHING	1
14	1806608	"0" RING	1
15	1806613	BACK-UP RING	1
16	8700708	ROD END L2-6576	1
17	1805222	JAM NUT 1-1/4 - 12	1
18	1800098	BRONZE BUSHING - 1-1/4" ID x 3" LONG	1

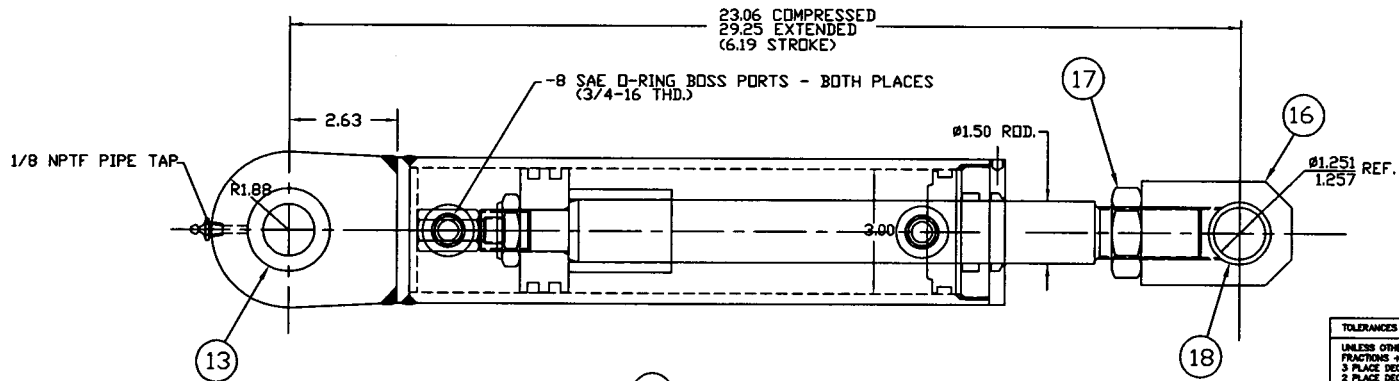
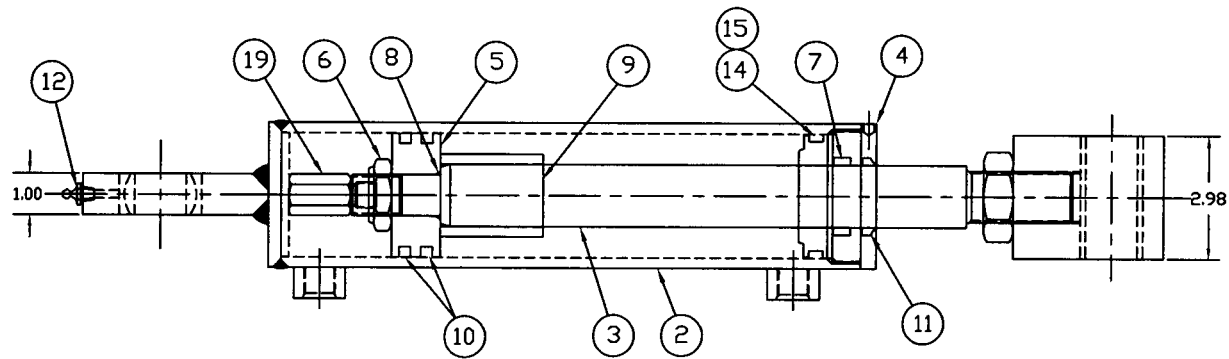

WORKING PRESSURE = 2500 PSI
PRIME PAINT

1 ASSEMBLY

TOLERANCES UNLESS OTHERWISE SPECIFIED FRACTIONS +/- 3 PLACE DECIMALS +/- 2 PLACE DECIMALS +/- 1 PLACE DECIMALS +/- ANGLES		SWINGMASTER CORPORATION 11415 MELROSE AVENUE FRANKLIN PARK, ILLINOIS 60131	
SEE SWINGMASTER SPECIFICATION 0-1 FOR TOLERANCES NOT SPECIFIED		STEERING CYLINDER - 6.19" STROKE MODEL 361	
DIMENSIONS ARE IN INCHES DO NOT SCALE DRAWING SCALE: 2=3		DRAWN BY: J.K. DATE: 10-18-05	DRAWING NO. D1-169

1	10-23-05	B/M ADDED.	2005006	J.K.
REV	DATE	DESCRIPTION	ENG. NO.	BY

MACHINE	SECTION	5
-----	-----	-----
MODEL 361 SWINGLOADER	STEERING SYSTEM	

ASSEMBLY NUMBER	DESCRIPTION
1802905	STEERING CYLINDER - 6.19" STROKE

ITEM NO.	PART NUMBER	DESCRIPTION	QTY USED
2	1806835	CASE WELDMENT	1
3	1806841	CYLINDER ROD	1
4	1806837	CAP	1
5	1806838	PISTON	1
6	1806839	LOCKNUT	1
7	1806610	ROD SEAL	1
8	1806604	"O" RING	1
9	1806842	SPACER	1
10	1806611	PISTON SEAL	2
11	1806612	WIPER	1
12	1800663	STRAIGHT 1/8" MALE-PIPE GREASE	1
13	1806176	SPHERICAL BUSHING	1
14	1806608	"O" RING	1
15	1806613	BACK-UP RING	1
16	8700708	ROD END L2-6576	1
17	1805222	JAM NUT 1-1/4 - 12	1
18	1800098	BRONZE BUSHING - 1-1/4" ID x 3" LONG	1
19	1806843	SPACER	1

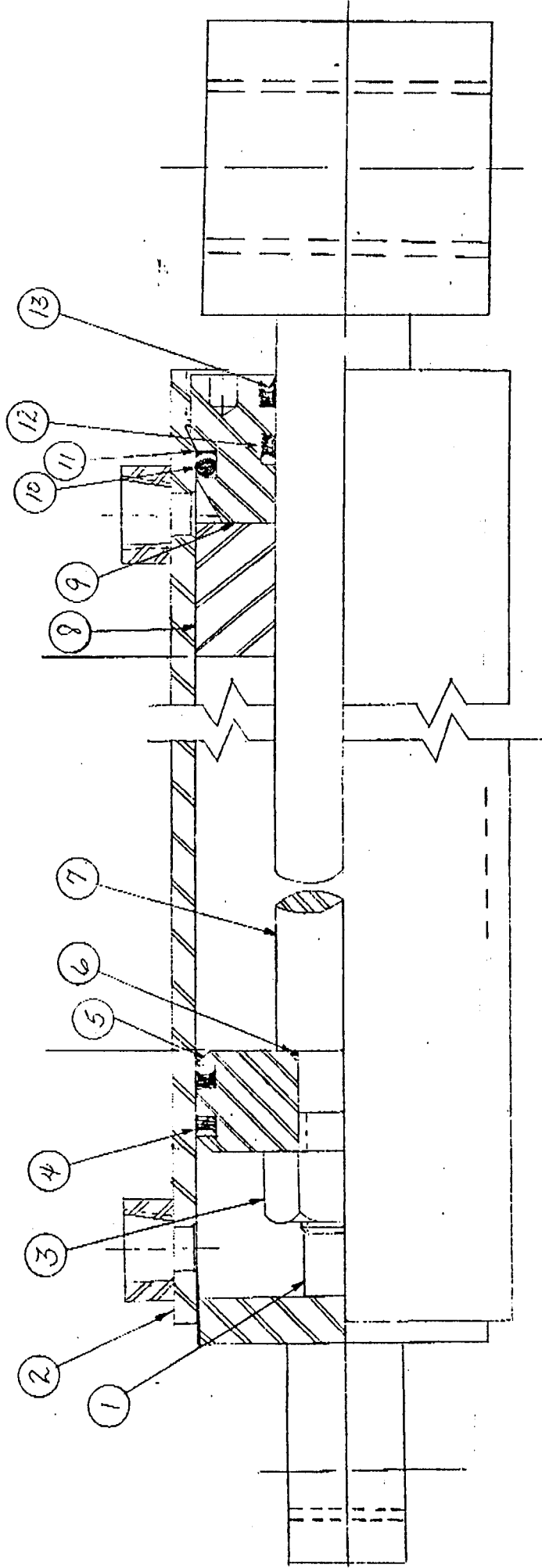

SWINGMASTER CORPORATION

PARTS BOOK

MACHINE ----- SECTION 5
MODEL 361 SWINGLOADER ----- STEERING SYSTEM -----

ASSEMBLY NUMBER -----	DESCRIPTION
1801988	STEERING CYLINDER - 10" STROKE
1802905	STEERING CYLINDER - 6.19" STROKE

ITEM PART NO. NUMBER DESCRIPTION	QTY. USED
1 8703297 STUD - USED ON 1802905 ONLY	1
2 TUBE ASSEMBLY	1
3 8703296 STOP NUT 1-14	1
4 8703287 POLYSEAL	2
5 8703288 PISTON	1
6 8703289 O-RING	1
7 8703290 ROD ASSEMBLY	1
8 8703298 SPACER - USED ON 1802905 ONLY	1
9 8703291 PACKING GLAND	1
10 8703292 O-RING	1
11 8703293 PARBACK	1
12 8703294 POLYSEAL	1
13 8703295 ROD WIPER	1
8703605 SEAL KIT	1

SWINGMASTER CORPORATION
11415 MELROSE AVENUE
FRANKLIN PARK, ILLINOIS 60131

TELEPHONE: (847) 451-1224

TERM NO.	WIRE NO.		TO	
	MODEL 181	MODEL 361	MODEL 181	MODEL 361
2, 4, 6, 8.	53	96	CIRC. BRKR #3	CIRC. BRKR. #30
1	8	8	SOL #1	SOL #1
3	9	7	SOL #2	SOL #2
5	10	6	SOL #3	SOL #3
7	11	5	SOL #4	SOL #4

STEERING
SELECTOR
VALVE.

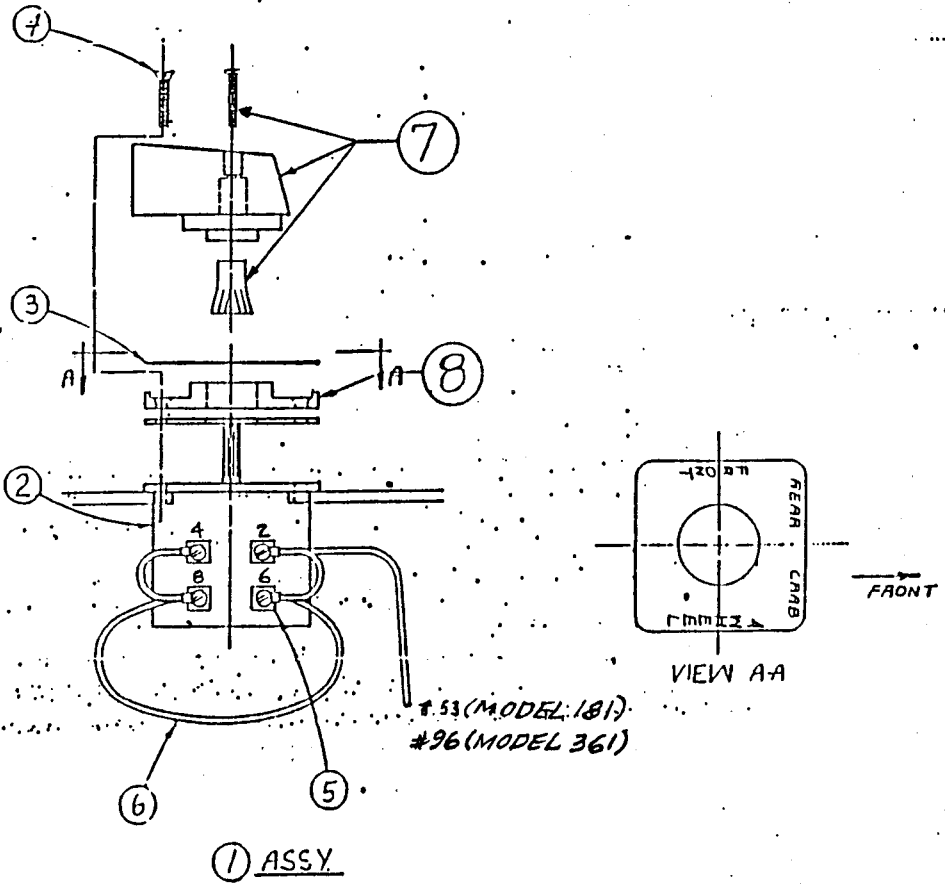

SWINGMASTER CORPORATION

PARTS BOOK

MACHINE

SECTION

5

MODEL 181 SWINGLOADER -----

STEERING SYSTEM -----

ASSEMBLY
NUMBER

DESCRIPTION

1801192

STEERING SELECTOR SWITCH INSTALLATION -----

ITEM NO.	PART NUMBER	DESCRIPTION	QTY. USED
2	1800245	4-POLE, ROTARY SWITCH	1
3	1801376	STEERING MODES SWITCH LABEL	1
4	1800846	FLAT HEAD MACHINE SCREW #6-32 X 1/2" LG	4
5	1801204	14 GAGE #6 ELECTRICAL RING TERMINAL	4
6	1801086	BULK 14 GAGE WIRE/(FT)	1
7	8701368	KNOB	1
8	8701369	ESCUTCHEON PLATE	1

SWINGMASTER CORPORATION
11415 MELROSE AVENUE
FRANKLIN PARK, ILLINOIS 60131

TELEPHONE: (847) 451-1224
