

SECTION U

TURNTABLE

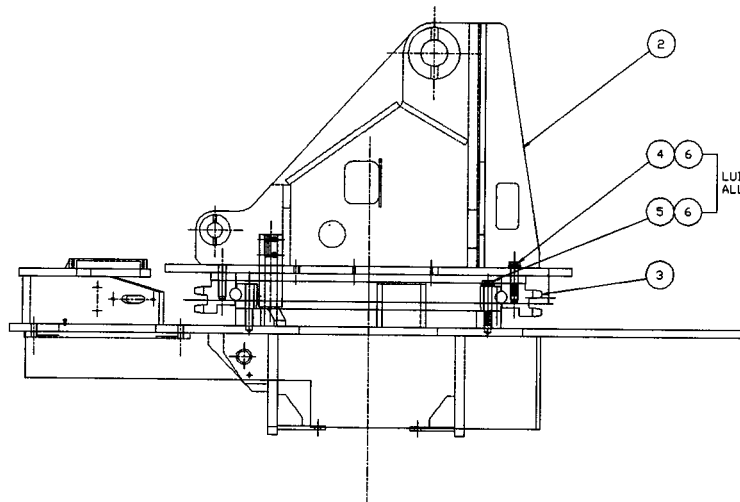
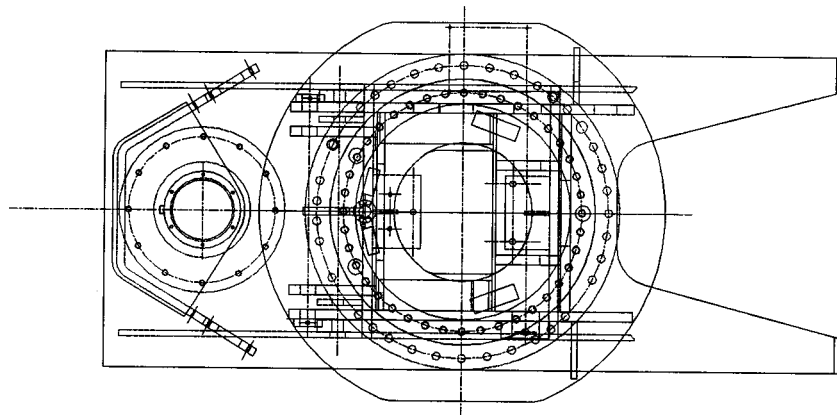

LUBRICATE AND TORQUE
ALL BOLTS TO 682-750 FT-LBS.

1 INSTALLATION

TOLERANCES
UNLESS OTHERWISE SPECIFIED
FRACTIONS +/-
3 PLACE DECIMALS +/-
2 PLACE DECIMALS +/-
1 PLACE DECIMALS +/-
ANGLES
SEE SWINGMASTER SPECIFICATION
C-1 FOR TOLERANCES NOT SPECIFIED
DIMENSIONS ARE IN INCHES
DO NOT SCALE DRAWING
SCALE 1=3

SWINGMASTER CORPORATION	
11415 MELROSE AVENUE FRANKLIN PARK, ILLINOIS 60131	
TURNTABLE INSTALLATION	
MODEL SL180-15	
DRAWN BY: J.K.	DRAWING NO.
DATE 9-8-98	D-804

MACHINE	SECTION	21
-----	-----	-----
MODEL SL180 SWINGLOADER	TURNTABLE	
-----	-----	-----

ASSEMBLY NUMBER	DESCRIPTION
-----	-----
1805908	TURNTABLE INSTALLATION
-----	-----

ITEM NO.	PART NUMBER	DESCRIPTION	QTY. USED
-----	-----	-----	-----
002	1805918	TURNTABLE WELDMENT	1.00
003	1803450	TURNTABLE BEARING	1.00
004	1805909	S.H.C.S. 1-8 x 3-1/2" LONG (GRADE 9)	35.00
005	1803452	S.H.C.S. 1-8 X 5" LONG	40.00
006	1803453	1" FLAT WASHER	75.00
007	1803454	REMOTE GREASE LINES & FITTINGS INSTALL.	1.00
-----	-----	-----	-----

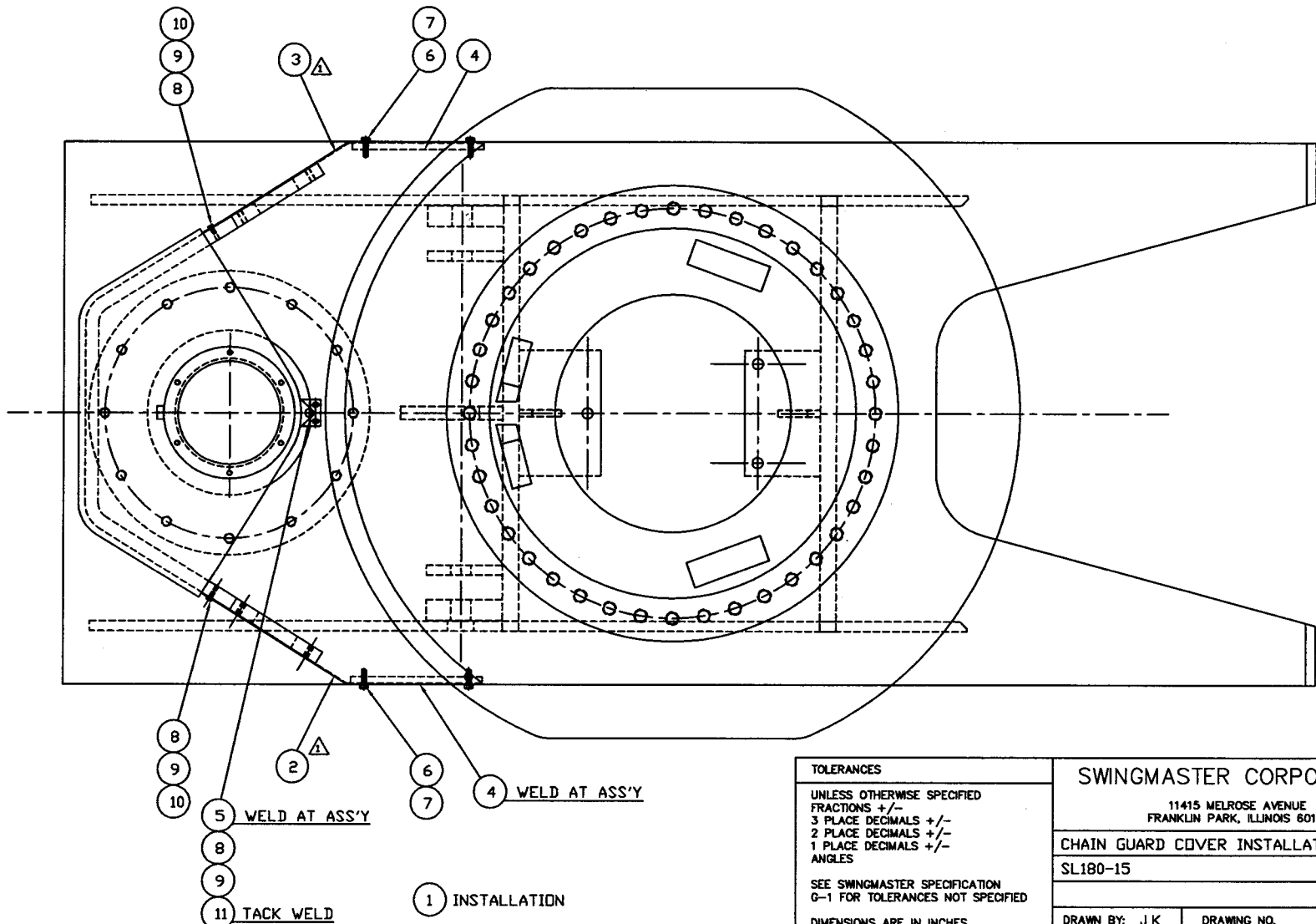

TOLERANCES
 UNLESS OTHERWISE SPECIFIED
 FRACTIONS +/- +/-
 3 PLACE DECIMALS +/-
 2 PLACE DECIMALS +/-
 1 PLACE DECIMALS +/-
 ANGLES

SEE SWINGMASTER SPECIFICATION
 G-1 FOR TOLERANCES NOT SPECIFIED

DIMENSIONS ARE IN INCHES
 DO NOT SCALE DRAWING
 SCALE: 1/6

SWINGMASTER CORPORATION
 11415 MELROSE AVENUE
 FRANKLIN PARK, ILLINOIS 60131

CHAIN GUARD COVER INSTALLATION
 SL180-15

DRAWN BY: J.K. DRAWING NO.
 DATE: 9-28-98 C-378

1-16-08	2 WAS C-377-1 & 3 WAS C-377-2	ED08001	J.K.
REV	DATE	DESCRIPTION	ENG. NO. BY

MACHINE	SECTION	21
-----	-----	-----
MODEL SL180 SWINGLOADER	TURNTABLE	
-----	-----	-----

ASSEMBLY	DESCRIPTION
NUMBER	-----
1806217	CHAIN GUARD COVER INSTALLATION
-----	-----

ITEM NO.	PART NUMBER	DESCRIPTION	QTY. USED
-----	-----	-----	-----
2	1806218	GUARD COVER - L.H.	1.00
3	1806219	GUARD COVER - R.H.	1.00
4	1806220	THREADED BAR	2.00
5	1806221	MOUNTING PLATE	1.00
6	1801433	H.H.C.S. 3/8-16 X 1/2" LONG	4.00
7	1800568	3/8" LOCK WASHER	4.00
8	1800430	H.H.C.S. 1/4-20 X 1/2" LONG	6.00
9	1800567	1/4" LOCK WASHER	6.00
10	1800548	1/4" FLAT WASHER	4.00
11	1800510	HEX NUT 1/4-20	2.00
-----	-----	-----	-----