

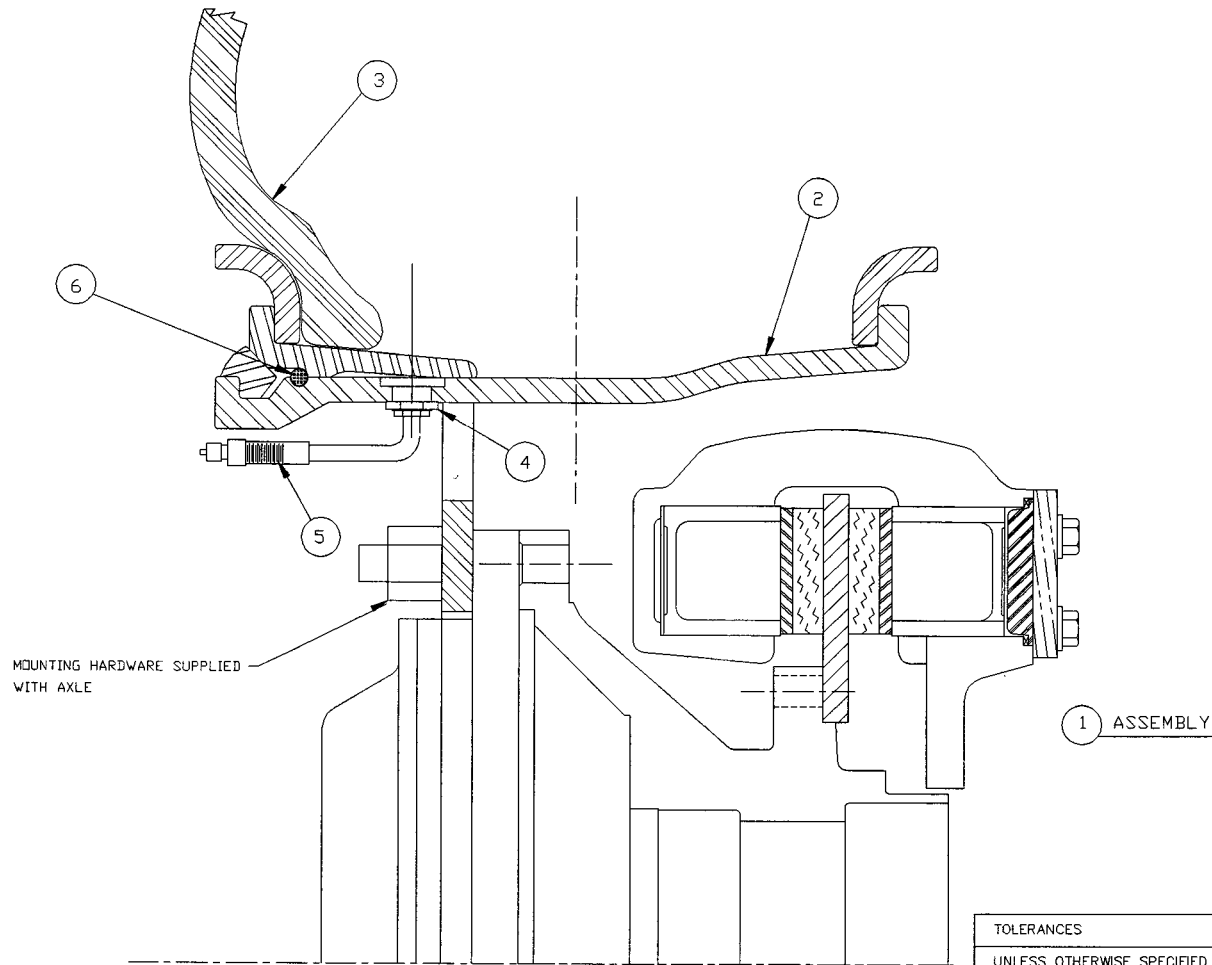

SECTION D

WHEELS
AND
TIRES



<p>TOLERANCES</p> <p>UNLESS OTHERWISE SPECIFIED</p> <p>FRACTIONS +/-</p> <p>3 PLACE DECIMALS +/-</p> <p>2 PLACE DECIMALS +/-</p> <p>1 PLACE DECIMALS +/-</p> <p>ANGLES</p> <p>SEE SWINGMASTER SPECIFICATION G-1 FOR TOLERANCES NOT SPECIFIED</p> <p>DIMENSIONS ARE IN INCHES</p> <p>DO NOT SCALE DRAWING</p> <p>SCALE: 1/2</p>		<p>SWINGMASTER CORPORATION</p> <p>730 INDUSTRIAL DRIVE ELMHURST, ILLINOIS 60126</p>	
		<p>WHEEL & TIRE ASS'Y</p>	
		<p>16.00 - 25 TUBELESS TIRE</p>	
		<p>MODEL 361 & SL180</p>	
		<p>DRAWN BY: J.K.</p> <p>DATE: 5-21-00</p>	<p>DRAWING NO.</p> <p>C3-102</p>

MACHINE	SECTION	4
---------	---------	---

MODEL SL180 SWINGLOADER	WHEELS AND TIRES
-------------------------	------------------

ASSEMBLY NUMBER	DESCRIPTION
--------------------	-------------

1806205	WHEEL & TIRE ASSEMBLY
---------	-----------------------

ITEM NO.	PART NUMBER	DESCRIPTION	QTY. USED
2	1803942	WHEEL ASSEMBLY - 11.25-25 SINGLE DISH	1.00
3	1805396	TIRE, RL-2F E-2 GRIP	1.00
4	1802077	TUBELESS SPUD	1.00
5	1806206	VALVE STEM	1.00
6	8704002	O-RING	1.00

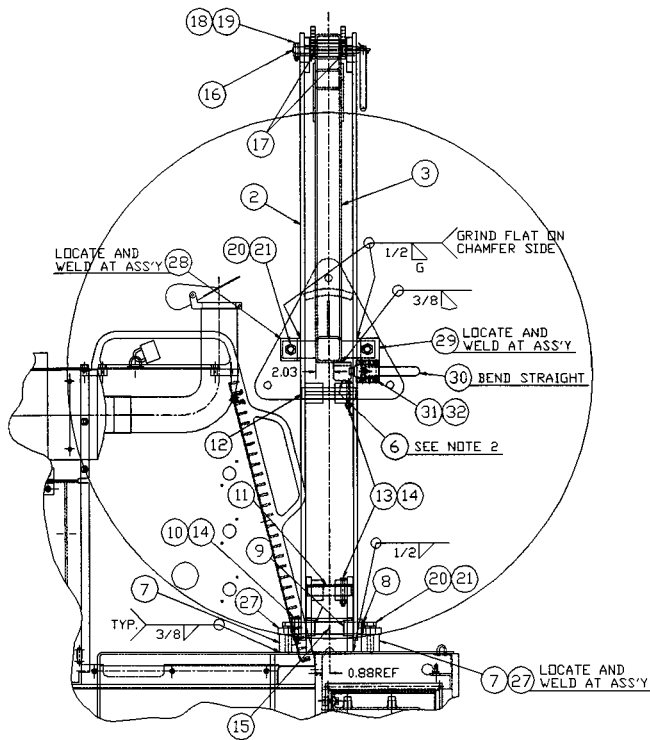
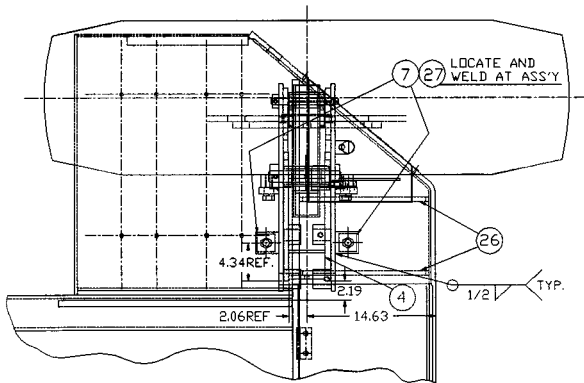

1 ASSEMBLY

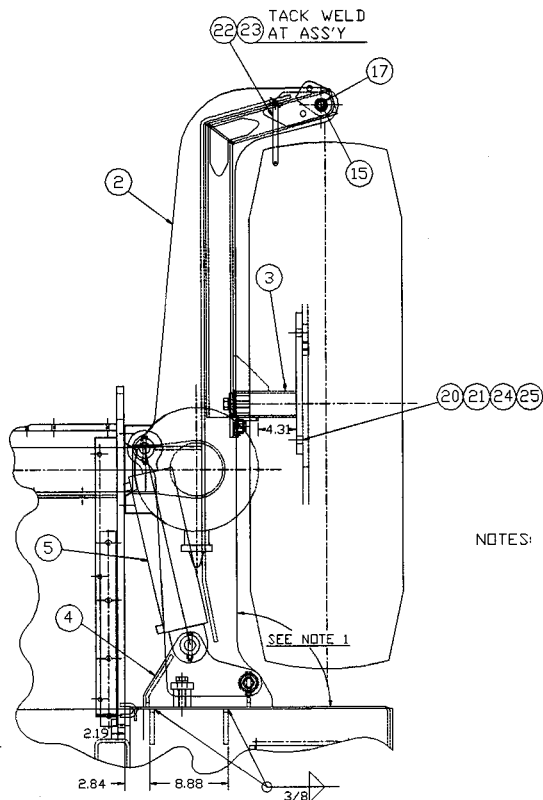

- NOTES:
1. SPARE TIRE MOUNT IS IN FULL UPRIGHT POSITION WHEN THIS ANGLE IS AT 90°; NOT WHEN THE CYLINDER IS FULLY RETRACTED
 2. ENGAGEMENT OF THE STRIKING PLATE MUST BE 3/16" HORIZONTALLY TO FUNCTION PROPERLY

TOLERANCES UNLESS OTHERWISE SPECIFIED FRACTIONS +/- 3 PLACE DECIMALS +/- 2 PLACE DECIMALS +/- 1 PLACE DECIMALS +/- ANGLES	SWINGMASTER CORPORATION 11415 MELROSE AVENUE FRANKLIN PARK, ILLINOIS 60131	
	HYDRAULIC SPARE TIRE MOUNT - ASSEMBLY	
SEE SWINGMASTER SPECIFICATION 0-1 FOR TOLERANCES NOT SPECIFIED	DRAWN BY: R.W.W. DATE: 9-16-98	DRAWING NO. D-807

MACHINE SECTION 30

 MODEL SL180 SWINGLOADER WHEELS AND TIRES

ASSEMBLY
 NUMBER DESCRIPTION

 1805921 HYD. SPARE TIRE MOUNT - ASSEMBLY

ITEM NO.	PART NUMBER	DESCRIPTION	QTY. USED
002	1805922	ARM WELDMENT	1.00
003	1805923	TIRE MOUNT WELDMENT	1.00
004	1805924	BRACKET WELDMENT	1.00
005	1805925	CYLINDER - 4" I.D.	1.00
006	1805972	STRIKING PLATE	1.00
007	1805927	TAPPED BAR	2.00
008	1805928	PIN - 1 1/4" DIA x 8 1/4" LONG	1.00
009	1805929	BUSHING	2.00
010	1805212	HHCS 3/8-16 X 2-3/4 LG	1.00
011	1805930	PIN - 1 1/4" DIA x 5 1/4" LONG	1.00
012	1805931	PIN - 1 1/4" DIA x 6 3/8" LONG	1.00
013	1800462	H.H.C.S. 3/8-16 X 3" LONG	2.00
014	1800515	ESNA HEX NUT 3/8-16	2.00
015	1800663	STRAIGHT 1/8" MALE-PIPE GREASE FITTING	4.00
016	1805932	PIN - 3/4" DIA x 7 3/4" LONG	1.00
017	1805933	BUSHING	2.00
018	1801957	H.H.C.S. 1/4-20 X 2 1/4" LONG	1.00
019	1801178	ESNA HEX NUT 1/4-20	1.00
020	1805935	H.H.C.S. 3/4-16 x 2.00" LONG	7.00
021	1800572	3/4" LOCK WASHER	7.00
022	1805934	5/8 DIA. BALL LOCK PIN - 6.50" LONG	1.00
023	1801511	MACHINE CHAIN (IN)	12.00
024	1800161	CAP NUT 3/4 - 16 x 1-1/8 - 16	3.00
025	1800160	CAP NUT 1-1/8 - 16	3.00
026	1805973	GUSSET	2.00
027	1805969	LOWER BRACKET	2.00
028	1805970	UPPER BRACKET - RIGHT	1.00
029	1805971	UPPER BRACKET - LEFT	1.00
030	1805974	SLAM LATCH	1.00
031	1801434	ROUND HEAD MACH SCREW #10-32 X 3/4" LONG	6.00
032	1800566	#10 LOCK WASHER	6.00

CYLINDER OPERATING PRESSURE : 2500 PSI.
 OVERLOAD RELIEF PRESSURE : 3000 PSI.

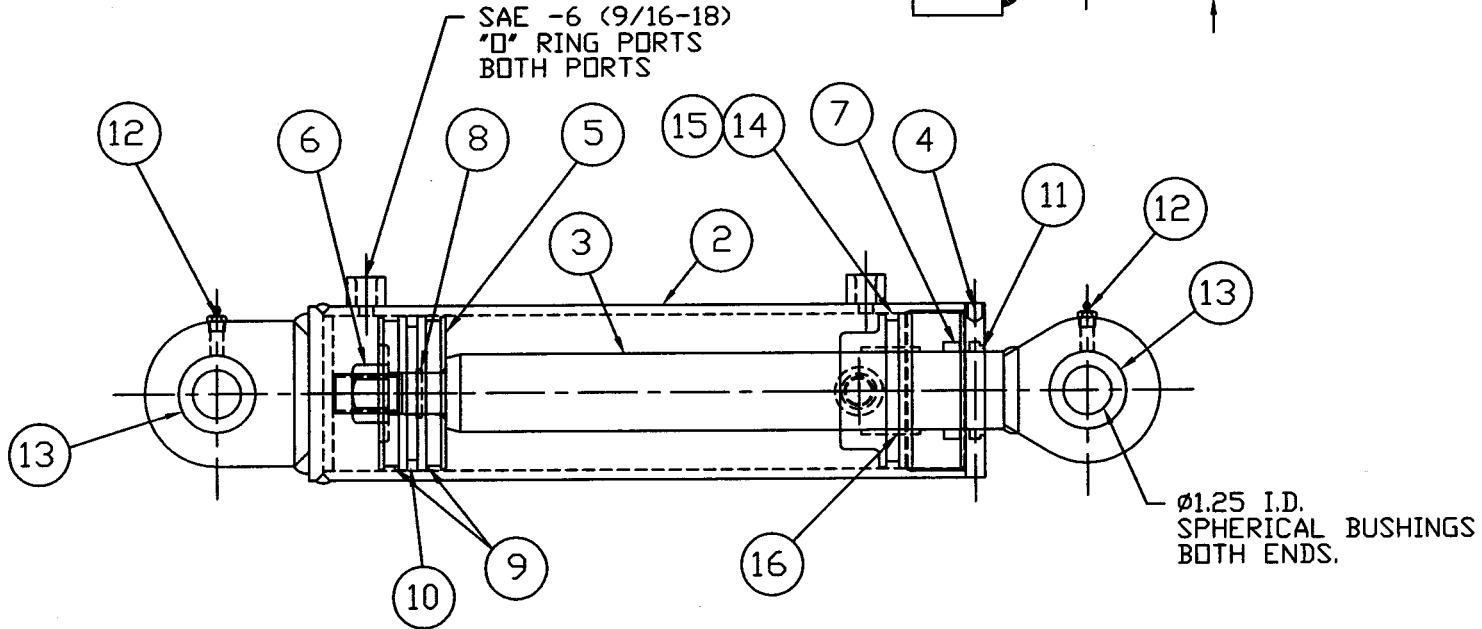
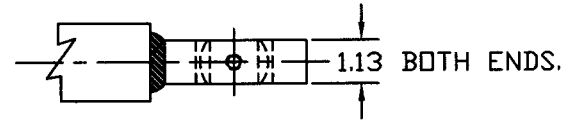

1 ASSEMBLY

NOTE :
 ALL MODEL : CONVERTS FROM 2007 SERIAL NUMBER.

TOLERANCES UNLESS OTHERWISE SPECIFIED FRACTIONS +/- 3 PLACE DECIMALS +/- 0.005 2 PLACE DECIMALS +/- 0.01 1 PLACE DECIMALS +/- ANGLES SEE SWINGMASTER SPECIFICATION TOLERANCES NOT SPECIFIED DIMENSIONS ARE IN INCHES DO NOT SCALE DRAWING SCALE NONE	SWINGMASTER CORPORATION 11415 MELROSE AVENUE FRANKLIN PARK, ILLINOIS 60131	
	HYDRAULIC CYLINDER	
	DRAWN BY: J.K. DATE: 11-30-06	DRAWING NO. C-373N
	(Empty space)	

MACHINE

SECTION

4

MODEL SL180 SWINGLOADER

WHEELS AND TIRES

ASSEMBLY
NUMBER

DESCRIPTION

1806651

HYD. CYLINDER ASS'Y

ITEM NO.	PART NUMBER	DESCRIPTION	QTY. USED
002	1806652	CASE WLDM'T	1.00
003	1806653	ROD WLDM'T	1.00
004	1806644	CAP	1.00
005	1806645	PISTON	1.00
006	1805655	GRIPCO LOCKNUT 1"-14	1.00
007	1806615	U-SEAL	1.00
008	1806618	"O" RINGG	1.00
009	1806619	WEAR RING	2.00
010	1806620	PISTON RING	1.00
011	1806614	WIPER	1.00
012	1800663	STRAIGHT 1/8" MALE-PIPE GREASE FITTING	2.00
013	1806176	SPHERICAL BUSHING	2.00
014	1806621	"O" RING	1.00
015	1806622	BACK-UP RING	1.00
016	1806616	WEAR RING	3.00

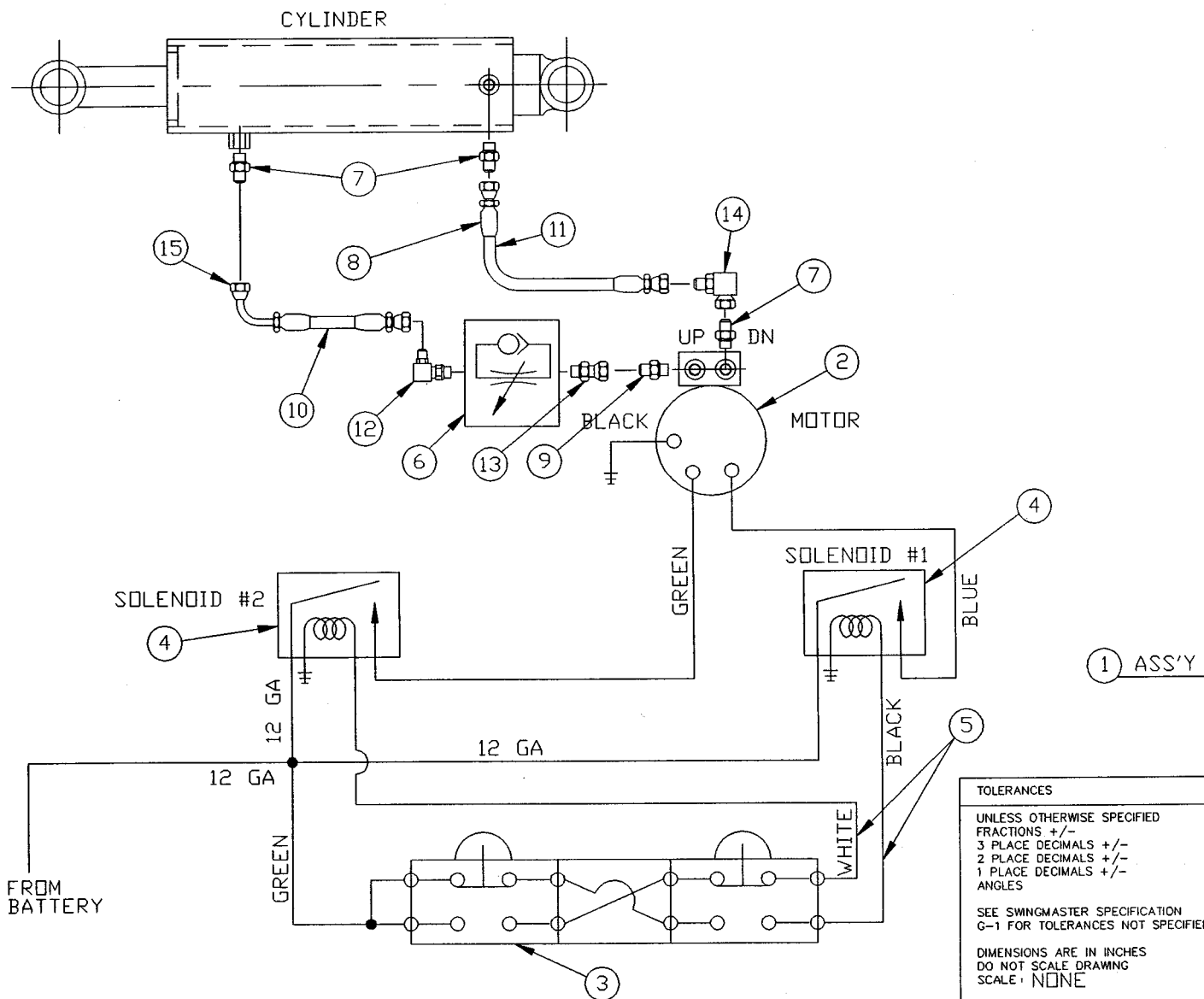

TOLERANCES

UNLESS OTHERWISE SPECIFIED

FRACTIONS +/-

3 PLACE DECIMALS +/-

2 PLACE DECIMALS +/-

1 PLACE DECIMALS +/-

ANGLES

SEE SWINGMASTER SPECIFICATION

G-1 FOR TOLERANCES NOT SPECIFIED

DIMENSIONS ARE IN INCHES

DO NOT SCALE DRAWING

SCALE: NONE

SWINGMASTER CORPORATION

11415 MELROSE AVENUE

FRANKLIN PARK, ILLINOIS 60131

HYD. MOTOR AND SWITCH SCHEMATIC

DRAWN BY: R.M.

DATE: 4-21-97

DRAWING NO.

H-394

MACHINE	SECTION	30
-----	-----	-----
MODEL SL180 SWINGLOADER	WHEELS AND TIRES	
-----	-----	-----

ASSEMBLY NUMBER	DESCRIPTION
-----	-----
1805966	ELECTRIC PUMP & WIRING INSTALLATION
-----	-----

ITEM NO.	PART NUMBER	DESCRIPTION	QTY. USED
-----	-----	-----	-----
002	1805967	HYDRAULIC PUMP	1.00
003	1805680	(2) BUTTON SWITCH	1.00
004	1800224	SOLENOID	2.00
005	1805681	18/3 SO CORDSWITCH	6.00
006	1805682	FLOW CONTROL VALVE	1.00
007	1803803	STRAIGHT MALE 1/4 O-RING TO 1/4 TUBE	3.00
008	1800976	STRAIGHT 1/4 TUBE F-1503-4	3.00
009	1802245	STRAIGHT MALE 1/4 O-RING TO 3/8 TUBE	1.00
010	1800705	1503-4 BULK HOSE/(IN)	1.00
011	1800705	1503-4 BULK HOSE/(IN)	1.00
012	1805022	O-RING ELBOW -4-6	1.00
013	1805686	SWIVEL ELBOW	1.00
014	1804552	90 DEG TUBE SWIVEL ELBOW 1/4-M TO 1/4-F	1.00
015	1800977	90 DEG SHORT ELBOW 1/4 UNI F-1503-4	1.00
-----	-----	-----	-----